



Public Works Department – Engineering Division

Date: April 15, 2024

ADDENDUM NO. 5

PROJECT 5067 WTP FILTER IMPROVEMENTS AND HYPOCHLORITE CONVERSION

NOTICE TO BIDDERS:

The following clarifications, amendments, additions and/or deletions as set forth herein shall apply to the above project contract documents and shall be made a part thereof and shall be subject to all the requirements thereof as though originally specified and/or shown. Submitters shall assure themselves that all addendum changes have been incorporated into their proposal.

A. ADDITIONS/DELETIONS/REVISIONS

1. On Drawing GC001, Detail 1, add the following note: “6. All flexible couplings shall be restrained.”
2. On Drawing A111, for Door Mark 500 in the Door Schedule, change Threshold Detail from “3A109” to “4/A111”.
3. On Drawing A110, below the Window and Louver Schedule, add the following comment for Window Mark W-2: “Provide safety glazing (tempered glass)”.
4. On Drawing A111, add the following note to Detail 4: “Threshold shall comply with the 2022 California Building Code, Chapter 11B-404.2.5.”
5. On Drawing GS002, Aluminum Handrail/Guardrail, change the reference in Note 4 from “2010 California Building Code” to “2022 California Building Code”.
6. On Drawing S002, add the following note to Detail 03125: “3. Safety nosing shall comply with the 2022 California Building Code, Chapter 11B-504.4.1.”
7. On Drawing GH001, and the following General Note: “9. HVAC systems including hydronic systems shall be balanced in accordance with AABC, ACCA Manual B, ASHRAE 111, NEBB or SMACNA standards. Provide balance report to the Construction Manager.”
8. On Drawings GH003, Detail 1, delete Note 2 in its entirety.
9. On Drawings GH003, Detail 2, Add Note 4: “Flexible air ducts shall not be more than five feet in length and shall not be used in lieu of rigid elbows or fittings.”
10. On Drawing GH004, replace Detail 4 with the detail below:

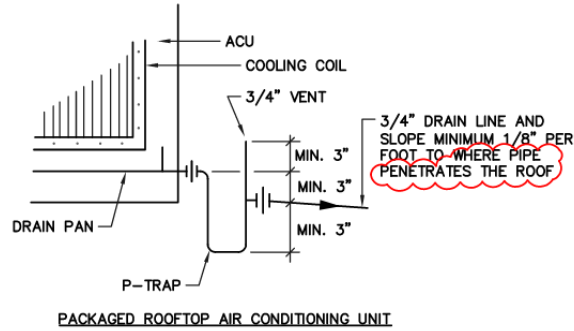

NOTES:

1. PROVIDE TRAP AS SHOWN AT COOLING COIL DRAIN CONNECTIONS.
2. PRIME TRAPS PRIOR TO STARTING FAN, AND AGAIN WHEN FAN IS IN CONTINUOUS OPERATION.
3. PROVIDE CLEANOUTS IN CONDENSATE LINES AT ALL CHANGES IN DIRECTION ALONG ITS ENTIRE LENGTH TO PERMIT CLEARING OF ANY BLOCKAGES.

④ CONDENSATE DRAIN DETAIL
 SCALE: NONE

11. On Drawing H103, Sheet 1 of 9, change the Total Unconditioned Floor Area from "0" to "1,666".
12. On Drawing H301, add following Sheet Note 3 "Exhaust duct termination shall be not less than 3 feet from a property line, 10 feet above a public walkway, and 3 feet from openings into the building." Added 3 feet clearance area around EF-2, shown below.

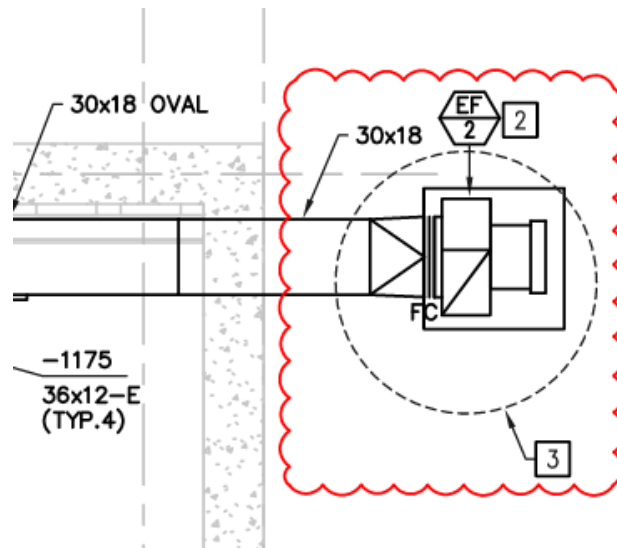

13. On Drawing H302, add the following general note: "A. Materials exposed within ducts or plenums shall have a flame-spread index of not more than 25 and smoke development rating not exceeding 50."

14. On Drawing H302, on Notes 2 and 3 after 48” minimum add the following: “and maximum of 60””.
15. On Drawing H303, add the following General Note: “A. Refrigerant piping exposed to weather shall be provided with a water retardant cover over the insulation. The use of adhesive tape is not acceptable.”
16. On Drawing H303, add following Sheet Note 5 “Exhaust duct termination shall be not less than 3 feet from a property line, 10 feet above a public walkway, and 3 feet from openings into the building.”
17. In Specification Section 23 03 00, Pipe Insulation Schedules have been added to section 2.2.B, see below.

B. Pipe Insulation Schedules:

Service	Temperature Range (degrees F)	Material	Insulation Thickness (inches) for Pipe Sizes:				
			< 1	1 < 1.5	1.5 to < 4	4 to < 8	8 and up
Domestic Hot Water	105 to 140	Glass fiber	1.0	1.5	1.5	1.5	1.5
Refrigerant	40 to 60	Glass fiber, Closed Cell	1.0	1.0	1.0	1.0	1.0
Refrigerant	Below 40	Glass fiber, Closed Cell	1.0	1.5	1.5	1.5	1.5

18. In Specification Section 23 03 00, Exterior Duct Insulation have been added to section 2.2.E.2, see below.

E. Ductwork, External:

1. Rectangular and Round Supply Air Ductwork: Glass fiber duct wrap insulation, minimum 1.0 pound density, FSK jacket, minimum 1-1/2 inches thick, Owens-Corning Type 100, or equal.
 - a. Insulate flexible connections above occupied areas with two (2) complete wraps of duct wrap insulation, each wrap individually applied and sealed.
2. Rectangular Supply and Return Air Ductwork on Roofs: Polyisocyanurate, FSK facing, minimum 1-1/2 inches thick, minimum 2.0 pounds per cubic foot density, rigid board insulation with excellent water resistance, R-Value of 6.0 per inch, minimum 20 psi compressive strength per ASTM D1621, rated for service from -40 to +250 degrees Fahrenheit, equal to Johns Manville, Rmax, or equal. Install with specified foil-backed self-adhering jacketing.
 - a. Build up insulation on top of ducts to shed water; slope to one side minimum 1/2-inch per foot.

19. In Specification Section 23 03 00, Exterior Duct Jacketing have been added to section 2.2.H, see below.

H. Jacketing for Exterior Duct Insulation:

1. Foil-Backed Self-Adhering Jacket for Exterior Rigid Duct Insulation: Polyguard "Alumaguard 60", 3M, or equal, laminated waterproof membrane consisting of a peel-and-stick rubberized bitumen adhesive compound with a cross-laminated high strength polyethylene backing film and aluminum foil surface. Minimum 60 mils thick, UV resistant, weatherproof and vapor proof. Install with "cold weather activator" by same manufacturer to improve adhesion.

20. On Drawing GPL003, Detail 1, add air release valves.

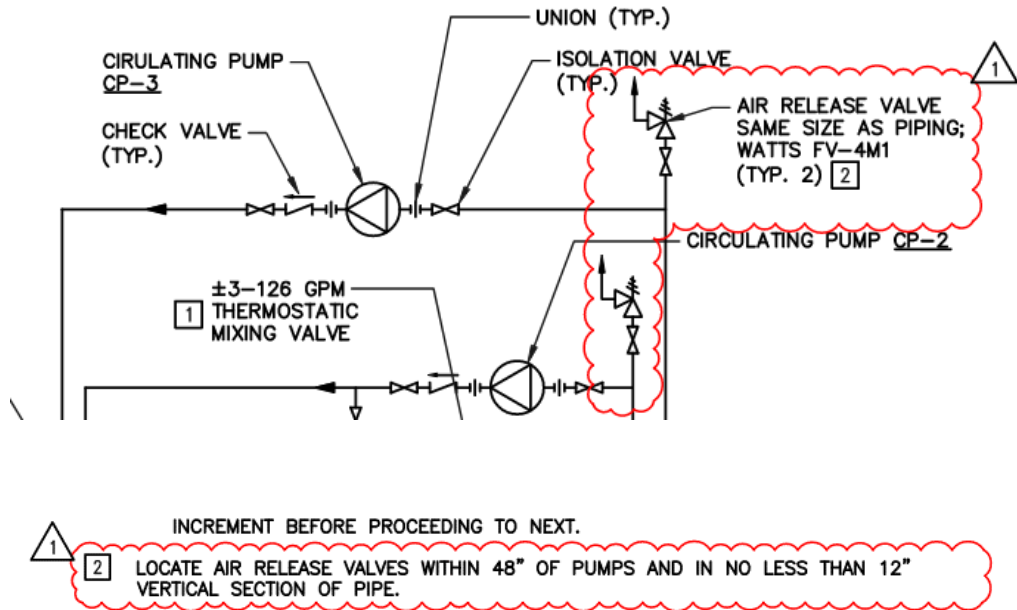

21. On Drawing GPL003, Detail 1, add a vacuum relief valve.

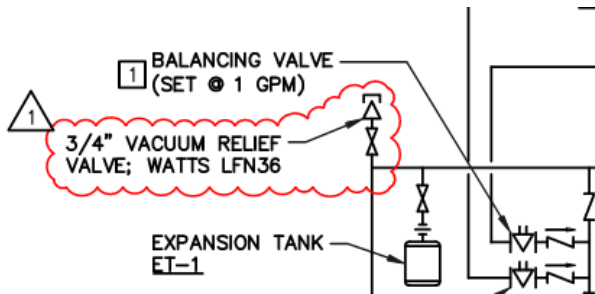

22. On Drawing GPL003, Detail 1, relocate heat trap to cold water inlet at mixing valve.

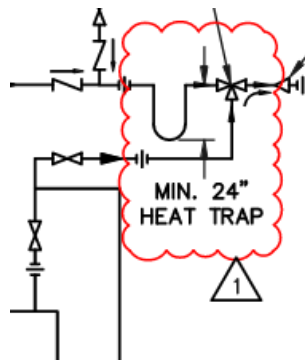

- 23. On Drawing GPL004, Sheet 1 of 7, add the address of the plant: "300 Olympia Drive, Pittsburg, CA 94565"
- 24. On Drawing PL300, add the following sheet note: "14. Path of travel to the eyewash station(s) shall be free of obstructions and clearly identified by signage. The eyewash station must be installed in accordance with the manufacturer's installation instructions."
- 25. On Drawing PL300, add the following sheet note: "15. Provide in and end of line cleanouts at midpoint and end of 100 feet runs of sanitary waste piping."
- 26. On Drawing PL300, add tags for sheet notes 14 and 15 to lower level plan.

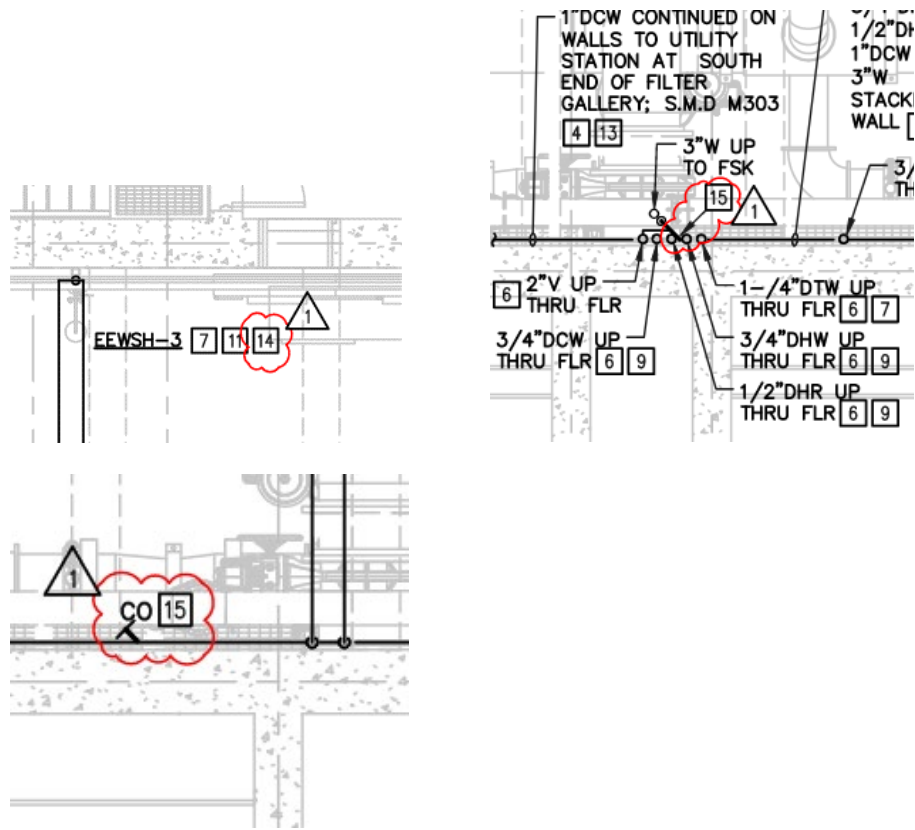

- 27. On Drawing PL300, add end of line cleanout to lower level plan at change in direction.

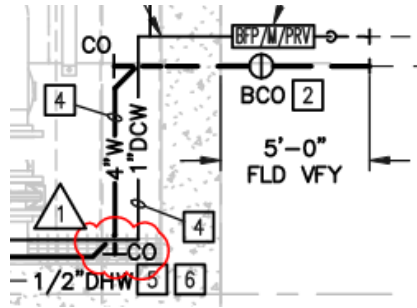

- 28. On Drawing PL641, add the following sheet note: “6. Path of travel to the eyewash station(s) shall be free of obstructions and clearly identified by signage. The eyewash station must be installed in accordance with the manufacturer’s installation instructions.”
- 29. On Drawing PL641, add tags for sheet note 6 to plan.

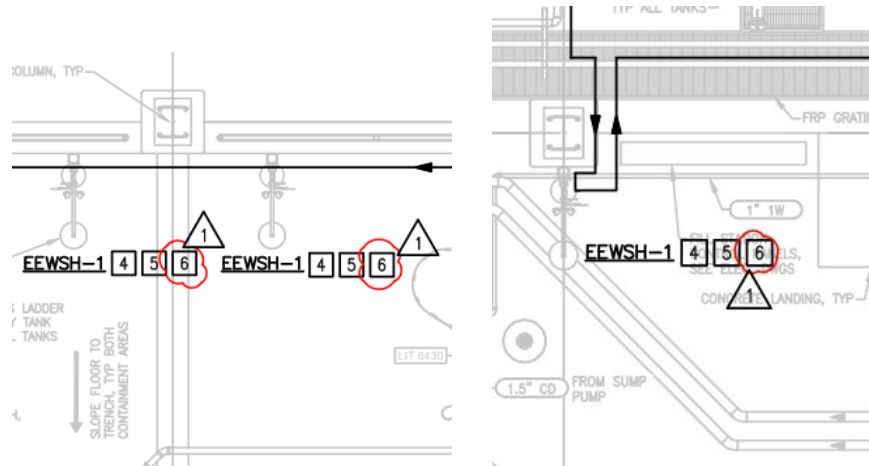

- 30. On Drawing GM005, Detail 10, add the following notes: “6. The path of travel to the eyewash and emergency showers shall be free of obstructions and clearly identified by signage.” And “7. The eyewash and emergency showers shall be installed in accordance with the manufacturer’s installation instructions.”
- 31. On Drawings GE010, GE011, GE012, GE031, GE032 and GE060, add the following notes (“2., 3., 3., 4., 3., and 3.”; respectively): “See Specification 26 05 33, Appendix A for Conduit Schedule.”
- 32. On Drawings GE010, GE011, GE012, GE031, GE032 and GE060, revise the single line diagram text for “DP31B” to “Distribution Panel #1”.
- 33. On Drawing E145, change the CB locations for EF-1 from “DP30A” to “DP30A” and CB location for EF-2 from “DP30A” to “DP31B” and CB location for EF-3 from “Lp30B” to “LP30A”.

34. On Drawings E302A and E303B, add the following notes (“4. and 6.”; respectively): “See Specification 26 50 00, Appendix A for Lighting Fixture Schedule.”
35. On Drawings E310, E311, E312, E400 and E641, add the following notes (“5., 2., 1., 1. and 1.”; respectively): “See Specification 26 05 33, Appendix A for Conduit Schedule.”
36. On Drawing E642, Note 4, change “Drawing E600” to “Drawing E660”
37. On Drawings E642, add the following note: “5. See Specification 26 50 00, Appendix A for Lighting Fixture Schedule.”
38. In Specification Section 03 30 00, Cast-in-Place Concrete, Paragraph 1.5 G, replace the following first sentence of the paragraph: “Testing of the following materials by an independent testing laboratory, acceptable to the Engineer, shall be engaged by and at the expense of the Contractor to verify conformity with this Specification Section and the stated ASTM Standard(s).” with the following: “Testing of the following materials by an independent testing laboratory shall be engaged by and at the expense of the Owner to verify conformity with this Specification Section and the stated ASTM Standard(s).”
39. In Specification Section 03 30 00, Cast-in-Place Concrete, Paragraph 1.5 H, replace the following first sentence of the paragraph: “The Contractor shall provide field testing services of the concrete by an independent testing agency, acceptable to the Engineer but employed by and at the expense of the Contractor.” with the following: “The Owner shall provide field testing services of the concrete by an independent testing agency at the expense of the Owner.”
40. In Specification Section 03 30 00, Cast-in-Place Concrete, Paragraph 3.8 A.2, replace the following first sentence of the paragraph: “Sets of field control concrete cylinder specimens in compliance with ASTM C31 and concrete bars for shrinkage testing shall be taken during the progress of the work by an independent testing agency, acceptable to the Engineer, employed by and at the expense of the Contractor.” with the following: “Sets of field control concrete cylinder specimens in compliance with ASTM C31 and concrete bars for shrinkage testing shall be taken during the progress of the work by an independent testing agency employed by and at the expense of the Owner.”
41. In Specification Section 03 30 00, Cast-in-Place Concrete, Paragraph 3.8 A.3, replace the following last sentence of the paragraph: “The Contractor shall provide a copy of all concrete test results to the District for their review.” with the following: “The Owner shall provide a copy of all concrete test results to the Contractor for review.”
42. In Specification Section 03 30 00, Cast-in-Place Concrete, Paragraph 3.8 A.5, replace the following second to last sentence of the paragraph: “All shipping of specimens will be paid for by the Contractor.” with the following: “All shipping of specimens will be paid for by the Owner.”

43. In Specification Section 03 30 00, Cast-in-Place Concrete, Paragraph 3.8 B.1, replace the following first sentence of the paragraph: "Slump tests will be made in the field immediately before placing the concrete by an independent testing agency, acceptable to the Engineer, employed by and at the expense of the Contractor." with the following: "Slump tests will be made in the field immediately before placing the concrete by an independent testing agency employed by and at the expense of the Owner."
44. In Specification Section 03 30 00, Cast-in-Place Concrete, Paragraph 3.8 C.1, replace the following first sentence of the paragraph: "Testing for air content shall be performed on a fresh concrete sample by an independent testing agency, acceptable to the Engineer, employed by and at the expense of the Contractor." with the following: "Testing for air content shall be performed on a fresh concrete sample by an independent testing agency employed by and at the expense of the Owner."
45. In Specification Section 03 30 00, Cast-in-Place Concrete, Paragraph 3.8 D.1, replace the following first sentence of the paragraph: "Field test specimens shall be handled and tested by an independent testing agency, acceptable to the Engineer, employed by and at the expense of the Contractor as specified herein under "Concrete Mixes"." with the following: "Field test specimens shall be handled and tested by an independent testing agency employed by and at the expense of the Owner as specified herein under "Concrete Mixes"."
46. In Specification Section 09 96 00, High Performance Coatings, Paragraph 1.6.H.2, replace the following sentence: "The specified quality control tasks shall be performed by a NACE-certified inspector hired and paid for by the Owner." with the following: "The specified quality control tasks shall be performed by a NACE-certified inspector hired and paid for by the Contractor."
47. In Specification Section 09 96 00, High Performance Coatings, Paragraph 3.8.C, add the following to the end of the sentence: "to provide additional testing beyond the Contractor's testing."
48. In Specification Section 09 96 00, High Performance Coatings, Paragraph 3.8.D, replace the following first sentence of the paragraph: "The Owner will perform such tests as are required to help ensure compliance with all phases of the surface preparation, and application of the coating systems." with the following: "The Contractor's NACE certified inspector shall perform such tests as are required to help ensure compliance with all phases of the surface preparation, and application of the coating systems."
49. In Specification Section 09 96 00, High Performance Coatings, Paragraph 3.8.F, replace the following first sentence of the paragraph: "The Owner will determine the degree and surface profile of the field blast cleaned surface per test method NACE RP0287." with the following: "The Contractor's NACE certified inspector shall determine the degree and surface profile of the field blast cleaned surface per test method NACE RP0287."

50. In Specification Section 09 96 00, High Performance Coatings, Paragraph 3.8.M.1, replace the following first sentence of the paragraph: "Provide personnel to operate coating film continuity detection devices under the direction of the Owner." with the following: "Provide personnel to operate coating film continuity detection devices under the direction of the Contractor's NACE certified inspector."
51. In Specification Section 09 96 00, High Performance Coatings, Paragraph 3.8.M.3.a, replace the following first sentence of the paragraph: "Perform test in presence of the Owner's Coating Inspector." with the following: "Perform test in presence of the Owner's representative."
52. In Specification Section 09 96 00, High Performance Coatings, Paragraph 3.8.Q, replace the following first sentence of the paragraph: "The Owner will verify completion of the final cure of the interior lining using a solvent wipe test." with the following: "The Contractor's NACE certified inspector will verify completion of the final cure of the interior lining using a solvent wipe test e
53. In Specification Section 10 73 16, Metal Canopies, Paragraph 1.5, insert the following subparagraph: "E. For the chemical storage area canopy, submit design calculations and detailing requirements for fall protection tie-off connections. Refer to Mechanical Drawings for additional details.
54. On Drawing S403, Detail 2: Please revise "#4 TIES @ 14" OC SP (MAX)" to "#4 TIES @ 12" OC SP (MAX)".
55. The bid date of April 18, 2024 at 2:00 pm is changed to April 23, 2024 at 2:00 pm.

B. CLARIFICATIONS AND QUESTIONS

Please be advised of the following clarifications to the contract documents:

1. PLA Section 2.3.1 includes "start-up, calibration, commissioning, performance testing, repair, maintenance, and operational revisions to systems or sub-systems". The field-service technicians that perform these duties, who are the authorized manufacturer representatives required by the technical specifications, are not union employees. They must be involved in the start-up, calibration, and testing requirements in order to satisfy the manufacturer's warranty requirements. Please remove this section from the PLA, or add an exception for authorized manufacturer representatives.

Response: This will be addressed in Addendum 6.

2. General Conditions 4.3 (F) Deductibles and Self-Insured Retentions requires that deductibles in excess of \$100,000 must be approved by the City's Risk Manager. Regarding Builder's Risk coverage, if coverage for the peril of earthquake is

required, please accept an earthquake deductible of 5% of the values at risk at time of loss, with a \$250,000 per occurrence minimum. Lower deductibles for earthquake in this seismic zone have limited availability and do not come at a reasonable cost.

Response: This will be addressed in Addendum 6.

3. California Public Contract Code Sec. 7105, the Act of God statute, provides Contractors relief from damages in excess of 5% of the contract value when caused by an earthquake (or resulting tidal wave) that registers 3.5 or higher on the Richter Scale. Code 7105 does permit an agency to require Contractors to provide earthquake insurance through a builders' risk insurance policy. When the agency elects to do so, the premium must be shown as a separate bid item. General Conditions 2.2 (B) makes the Contractor responsible for damage to the work caused by earthquake, but General Conditions 4.3 (A) (5) Builder's Risk Insurance only calls for coverage to be on an all-risk or "all perils" basis. Per industry standards, all risk / all perils policies do not automatically include coverage for the peril of earthquake. Please either amend General Conditions 2.2 (B) Responsibility for the Work and Risk of Loss to include relief as provided by Section 7105, or amend General Conditions 4.3 (A) (5) Builder's Risk Insurance to specifically require coverage for earthquake with a sublimit no greater than \$40,000,000 per occurrence and annual aggregate per commercially available limits in this seismic zone, which would also require a bid line item for the earthquake premium.

Response: This will be addressed in Addendum 6.

4. Per General Conditions, Article 2, Contractor 2.2(B), Contractor bears all risks of injury or damage to the Work and the materials and equipment delivered to any Worksite, by any cause including fire, earthquake, wind, weather, vandalism or theft and Article 4, Insurance 4.3A(5), The builder's risk insurance policy must be issued on an occurrence basis, for all-risk or "all perils" coverage. Pursuant to PCC 7105, Contractors are not responsible to the public agency for repairing or restoring damages caused by an Act of God in excess of 5% of the contracted amount. If coverage for Acts of God are required, a separate bid item for this coverage is required. Please confirm the requirement for such policy shall exclude Acts of God as defined in PCC 7105.

Response: This will be addressed in Addendum 6.

5. General Conditions Article 7.8.C states that the City will bear the initial cost of inspection and testing. However, Volume 1 Division 01 Spec 01 45 00 Part 1.2.B states the Contractor shall employ and pay a qualified independent testing agency where individual Sections specifically indicate the Contractor is responsible for certain inspections, tests, and QC services. These two statements contradict and following the Order of Precedence in the General Conditions Article 3.2, the General Conditions are of higher precedence than the

Specifications. Please confirm if the City will bear the costs of inspections and testing or if the bidding contractors shall follow the individual specification sections to determine responsibility.

Response: The Owner will perform and pay for quality control testing for soil and earthwork quality control testing, concrete quality control testing and the specialty inspections identified on Drawing GS003 unless otherwise noted in the specifications or on the drawings. The Contractor shall perform all other testing such as coatings, hydraulic testing for structures, pipe pressuring testing, equipment related testing; etc. shall be performed and paid for the Contractor.

6. Please advise what subgrade prep is required below the filter gallery and filter area foundation slab.

Response: Subgrade preparation below the filter gallery and filter area foundation slab shall be in accordance with Detail 02001 that was included in Addendum #3.

BIDDERS MUST SIGN AND ATTACH one (1) copy of this addendum document to the proposal as acknowledgment of receipt of these instructions and that said addendum was properly evaluated in the proposal.

ANY PROPOSAL NOT IN COMPLIANCE WITH THIS ADDENDUM MAY BE REJECTED.

Issued: 04-15-2024



Dayne Johnson, P.E.
Assistant City Engineer

ADDENDUM NO. 5, PROJECT 5067 WTP FILTER IMPROVEMENTS AND HYPOCHLORITE CONVERSION is hereby acknowledged and was considered in this Project Proposal.

Bidder's Signature

Date

Firm Name

Mailing Address

City/State/Zip+4