

GENERAL NOTES

- ALL DRAWINGS AND SPECIFICATIONS ARE CONSIDERED PART OF THE CONTRACT DOCUMENTS. THE CONTRACTOR SHALL BE RESPONSIBLE FOR REVIEW AND COORDINATION OF ALL DRAWINGS AND SPECIFICATIONS PRIOR TO CONSTRUCTION. ANY DISCREPANCIES THAT OCCUR SHALL BE BROUGHT TO THE ATTENTION OF THE ENGINEER PRIOR TO THE START OF CONSTRUCTION SO THAT A CLARIFICATION MAY BE ISSUED. WORK NOT CONFORMING TO THE CONTRACT DOCUMENTS SHALL BE CORRECTED BY THE CONTRACTOR TO AT NO EXPENSE TO THE CITY.
- THE CONTRACTOR AGREES THAT IN ACCORDANCE WITH GENERALLY ACCEPTED PRACTICES, THAT CONTRACTOR SHALL ASSUME SOLE AND COMPLETE RESPONSIBILITY FOR CONDITIONS AT THE JOB SITE AND SAFETY OF THE WORK DURING THE COURSE OF THE PROJECT. THESE PLANS DO NOT INCLUDE NECESSARY COMPONENTS FOR CONSTRUCTION SAFETY.
- THE CONTRACTOR SHALL AT ALL TIMES COMPLY WITH THE CONSTRUCTION SAFETY ORDERS AS SET-FORTH IN THE CALIFORNIA CODE OF REGULATIONS.
- THE CONTRACTOR SHALL AT ALL TIMES COMPLY WITH THE NATIONAL POLLUTION DISCHARGE ELIMINATION SYSTEM (NPDES) WATER POLLUTION CONTROL BEST MANAGEMENT PRACTICES (BMP).
- THE CONTRACTOR SHALL AT ALL TIMES COMPLY WITH THE CITY STANDARD PLANS AND SPECIFICATIONS. THE CONTRACTOR SHALL COMPLY WITH THE LATEST CALTRANS STANDARD PLANS AND SPECIFICATIONS.
- NOT NECESSARILY ALL UNDERGROUND FACILITIES ARE SHOWN. THE CONTRACTOR IS SOLELY RESPONSIBLE TO VERIFY THE EXACT LOCATION AND DEPTH OF ALL EXISTING UTILITIES WITHIN THE HORIZONTAL AND VERTICAL LIMITS OF THE WORK AREA PRIOR TO COMMENCING ANY EXCAVATION. THE CONTRACTOR SHALL NOTIFY UNDERGROUND SERVICE ALERT AT (800) 227-2600 OR 811 AT LEAST TWO WORKING DAYS, BUT NOT MORE THAN 14 CALENDAR DAYS PRIOR TO COMMENCING. THAT EXCAVATION, IF THE EXCAVATION WILL BE CONDUCTED IN AN AREA THAT IS KNOWN, OR REASONABLY SHOULD BE KNOWN, TO CONTAIN SUBSURFACE INSTALLATIONS.
- THE CONTRACTOR SHALL DELINEATE WITH WHITE PAINT OR OTHER SUITABLE MARKINGS THE AREA TO BE EXCAVATED. CONTACTING U.S.A. DOES NOT RELIEVE THE CONTRACTOR FROM THE CONTRACTOR'S RESPONSIBILITY TO DETERMINE THE EXACT LOCATION AND DEPTH OF SUBSURFACE INSTALLATIONS. POTENTIAL SHALLOW UTILITIES NOT PER STANDARD INSTALL COULD BE FOUND.
- SERVICE LATERALS AND APPURTENANCES ARE NOT SHOWN ON THE PLANS. CONTRACTOR IS SOLELY RESPONSIBLE TO DETERMINE THE EXACT LOCATION AND DEPTH OF EXISTING SERVICE LATERALS OR APPURTENANCES WHENEVER THE PRESENCE OF SUCH ON THE SITE OF THE CONSTRUCTION PROJECT CAN BE INFERRED FROM THE PRESENCE OF OTHER VISIBLE FACILITIES, SUCH AS BUILDINGS, METER AND JUNCTION BOXES, LOCATED ON OR ADJACENT TO THE SITE OF THE CONSTRUCTION OR OTHERWISE WHERE MAIN OR TRUNKLINES ARE SHOWN ON THE PLANS OR INFERRED.
- THE FACT THAT ANY UNDERGROUND FACILITY IS NOT SHOWN UPON THE PLANS SHALL NOT RELIEVE THE CONTRACTOR OF THE RESPONSIBILITY UNDER SECTION 8 1.10, "UTILITY AND NON HIGHWAY FACILITIES." IT SHALL BE CONTRACTOR'S SOLE RESPONSIBILITY, PURSUANT THERETO, TO ASCERTAIN THE LOCATION OF THOSE UNDERGROUND IMPROVEMENTS OR FACILITIES WHICH MAY BE SUBJECTED TO DAMAGE BY REASON OF THE CONTRACTOR'S OPERATIONS.
- THE CONTRACTOR SHALL LOCATE, REFERENCE, AND SET SUFFICIENT MARKS NECESSARY TO RE-ESTABLISH LOCATIONS OF FRAMES AND COVERS OF UTILITY FACILITIES PRIOR TO COMMENCEMENT OF WORK. CONTRACTOR SHALL RENEW REFERENCE MARKS WITH THE ENGINEER AND PUBLIC WORKS OPERATIONS PERSONNEL. IN AREAS WHERE BITUMINOUS SEALS ARE TO BE PLACED, THE FRAMES AND COVER OF UTILITY FACILITIES SHALL BE MASKED PRIOR TO COMMENCEMENT OF WORK.
- WHERE EXISTING PAVEMENT LEGENDS AND LINES ARE SHOWN TO BE REMOVED, THE EXISTING MARKINGS SHALL BE REMOVED COMPLETELY. WHERE EXCESSIVE DAMAGE OR SCARRING RESULTS FROM THE REMOVAL, THE CONTRACTOR SHALL APPLY A SURFACE TREATMENT OR SEALANT PER SPECIFICATIONS TO 1-FOOT BEYOND THE EDGES OF THE REMOVED MARKINGS.
- THE CONTRACTOR SHALL BE SOLELY RESPONSIBLE FOR ANY DAMAGES TO THE SITE OR THE SURROUNDING AREA AS A RESULT OF THE CONTRACTOR'S WORK OR OPERATIONS. EXISTING CURB AND GUTTER, TRAFFIC LINES AND MARKINGS, OR OTHER IMPROVEMENTS THAT ARE DAMAGED OR DISPLACED BY THE CONTRACTOR SHALL BE REPLACED AT THE CONTRACTOR'S SOLE EXPENSE.
- TRAFFIC CONTROL DURING CONSTRUCTION SHALL BE THE CONTRACTOR'S RESPONSIBILITY. ALL SIGNS AND TRAFFIC CONTROL DEVICES SHALL BE IN ACCORDANCE WITH THE LATEST EDITION OF THE CALIFORNIA MANUAL ON UNIFORM TRAFFIC CONTROL DEVICES.
- CONTRACTOR SHALL PROVIDE FOR CONTINUOUS INGRESS AND EGRESS TO ALL PRIVATE PROPERTIES ADJACENT TO THE WORK THROUGHOUT THE PERIOD OF CONSTRUCTION UNLESS OTHERWISE APPROVED BY THE CITY.
- WHEN PLANNED CONSTRUCTION OPERATIONS WILL TEMPORARILY OBSTRUCT OR BLOCK A DRIVEWAY, CONTRACTOR SHALL PROVIDE OWNER/TENANTS WRITTEN NOTICE 72 HOURS PRIOR TO PLANNED CONSTRUCTION. PROOF OF NOTICE SHALL BE PROVIDED TO THE CITY.
- ALL STREET MONUMENTS AND OTHER PERMANENT MONUMENTS DISTURBED DURING CONSTRUCTION SHALL BE REPLACED BY THE CONTRACTOR, AT THE CONTRACTOR'S SOLE EXPENSE. BEFORE THE IMPROVEMENTS ARE ACCEPTED BY THE CITY, REPLACEMENT SHALL BE MADE UNDER THE DIRECTION OF A LICENSED PROFESSIONAL LAND SURVEYOR.

STRIPING NOTES

- ALL STRIPING SHALL CONFORM TO THE DESIGN AND CONSTRUCTION STANDARDS OF THE CITY OF PITTSBURGH, THE LATEST EDITION OF THE CALTRANS STANDARD PLANS AND SPECIFICATIONS, AS WELL AS THE MANUAL ON UNIFORM TRAFFIC CONTROL DEVICES (MUTCD).
- THE CONTRACTOR SHALL NOTIFY THE CITY ENGINEER A MINIMUM OF TWO (2) WORKING DAYS PRIOR TO THE DAY OF LAYOUT OF PROPOSED STRIPING. NO STRIPING OR LEGENDS SHALL BE INSTALLED UNTIL LAYOUT HAS BEEN APPROVED BY THE CITY ENGINEER OR HIS REPRESENTATIVE.
- THE CONTRACTOR SHALL BE RESPONSIBLE FOR LAYOUT OF ALL PROPOSED STRIPING.
- ALL STRIPING AND LEGENDS SHALL BE THERMOPLASTIC MATERIALS WITH GLASS BEADS PER CALTRANS AND MUTCD STANDARDS.
- ALL CROSSWALKS SHALL BE 10' WIDE INSIDE DIMENSION AND CONSIST OF 12" WHITE THERMOPLASTIC STRIPES UNLESS OTHERWISE NOTED (E.G. CROSSWALKS WITHIN 600 FT OF A SCHOOL SHALL BE YELLOW).
- INSTALL BLUE REFLECTIVE PAVEMENT MARKERS AT ALL FIRE HYDRANT LOCATIONS. THE PAVEMENT MARKERS ARE TO BE LOCATED IN LINE WITH THE FIRE HYDRANT IN THE MIDDLE OF THE OUTSIDE LANE.
- REPLACE ALL EXISTING STRIPING AS IT CURRENTLY EXISTS UNLESS A NEW STRIPING DESIGN IS SHOWN ON THE STRIPING PLANS.
- TRAFFIC LOOP DETECTORS SHALL BE INSTALLED AS SHOWN ON STRIPING PLANS. BIKE LANE LOOP DETECTORS SHALL BE CALTRANS TYPE C, AND MOTOR VEHICLE LANE LOOP DETECTORS SHALL BE TYPE E.
- SEE TECHNICAL SPECIFICATION "TRAFFIC SIGNALS AND LIGHTS" FOR ALL TRAFFIC LOOP DETECTOR SPECIFICATIONS. SEE SECTIONS 34 41 00 - 15 AND 34 41 00 - 43 FOR VEHICLE DETECTION SYSTEMS AND INDUCTIVE LOOP INSTALLATION SPECIFICATIONS.

PAVING NOTES

- EXACT LOCATIONS AND DIMENSIONS OF BASE REPAIR / DIG OUTS SHALL BE DETERMINED AND MARKED IN THE FIELD BY THE CONTRACTOR AND ENGINEER. THE AGREED UPON DIMENSIONS SHALL BE RECORDED BEFORE THE START OF ANY BASE REPAIR WORK AS THIS WILL BE THE MEASUREMENT OF PAYMENT AND NO ADDITIONAL WORK OUTSIDE THE AGREED UPON AREA WILL BE PAID FOR.
- MICRO SURFACING SHALL BE APPLIED TO LANE NO. 1 AS SHOWN ON SHEET N-2, DETAIL 1. LANE NO. 2 WILL RECEIVE A 2-INCH MILL AND OVERLAY AS SHOWN IN DETAIL 11. SEE LAYOUT PLANS FOR WORK LIMITS.
- AFTER BASE REPAIR, HMA (TYPE A) PLUG SHALL BE PLACED IN LIFTS WITH PAVING MACHINE AS SHOWN IN DETAIL 10 BELOW.
- TACK COAT SHALL BE APPLIED TO ALL SURFACES PRIOR TO PLACEMENT OF EACH LIFT OF HMA AS SHOWN ON DETAIL 10.
- DEPTH OF PAVEMENT REPAIRS SPECIFIED ON THE PLANS SHALL BE MEASURED FROM THE EXISTING PAVEMENT SURFACE.
- AGGREGATE FOR ASPHALT CONCRETE BASE FAILURE REPAIRS, ASPHALT CONCRETE PAVEMENT REPAIRS, WEDGE COURSES, BOTTOM LAYERS OF ASPHALT CONCRETE AND BOTTOM LAYER OF ASPHALT CONCRETE INLAYS SHALL BE THE 3/4-INCH HMA TYPE A AGGREGATE GRADATION SPECIFIED IN SECTION 39, "AGGREGATE" OF THE CALTRANS STANDARD SPECIFICATION.
- AGGREGATE FOR ASPHALT CONCRETE OVERLAYS, TOP LAYER OF ASPHALT CONCRETE, TOP LAYER OF ASPHALT CONCRETE INLAYS, AND LEVELING COURSES, SHALL BE TYPE A HMA WITH 1/2-INCH NOMINAL MAXIMUM SIZE AGGREGATE (AS PER CALTRANS STANDARD SPECIFICATION).

ABBREVIATIONS

AB	AGGREGATE BASE
AC	ASPHALTIC CONCRETE OR ACRE
AD	CHANGE IN GRADE
BCR	BEGINNING OF CURB RETURN
CONC	CONCRETE
CL	CENTERLINE
CONST	CONSTRUCT
CTE	CONFORM TO EXISTING
DWY	DRIVEWAY
ECR	END OF CURB RETURN
EX	EXISTING
EP	EDGE OF PAVEMENT
EASE	EASEMENT
FG	FINISH GRADE
FH	FIRE HYDRANT
HMA	HOT MIX ASPHALT
L	LENGTH
LL	LIMIT LINE (12" WHITE LINE)
MAX	MAXIMUM
MIN	MINIMUM
NTS	NOT TO SCALE
PI	POINT OF INTERSECTION
PL	PROPERTY LINE
R/W	RIGHT OF WAY
STA	STATION
TEMP	TEMPORARY
TYP	TYPICAL

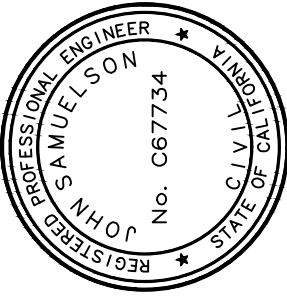

PREPARED UNDER THE DIRECTION OF:
 JOHN SAMUELSON
 RCE 067734
 Date: 7/12/23

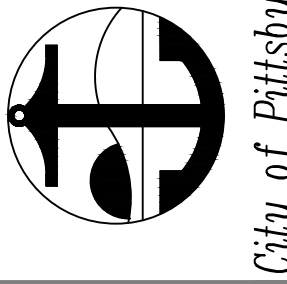

PROJECT 2241
E LELAND ROAD PAVEMENT MAINTENANCE
PROJECT NOTES

BY	DRAWN: SR	CHECKED: SR	REVIEWED: DJ	DATE: 7/12/23	SCALE: N/A
----	-----------	-------------	--------------	---------------	------------

DATE	REV	DESCRIPTION

SHEET:
2 OF 15

SHEET NO.
G-1

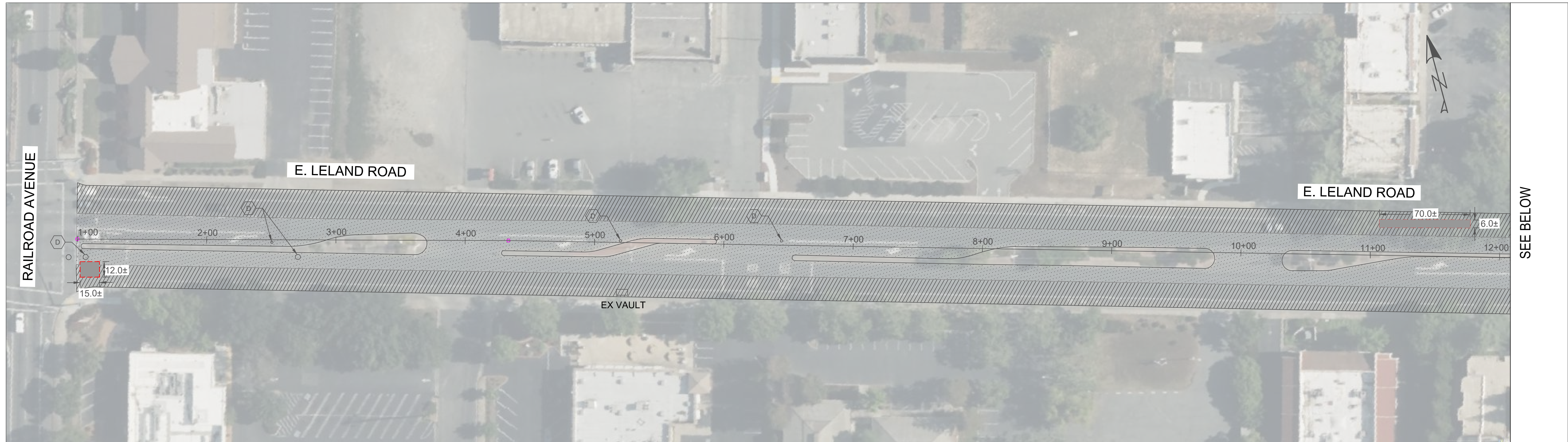

E. LELAND ROAD: FROM STA. 1+00 TO STA. 12+00

SEE BELOW

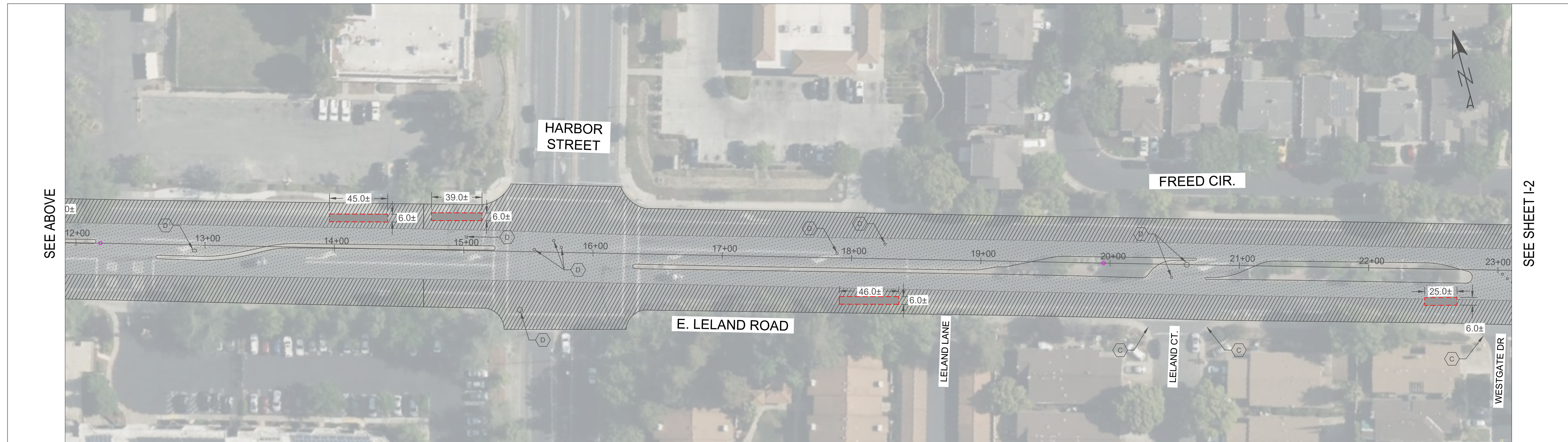

E. LELAND ROAD: FROM STA. 12+00 TO STA. 23+00

SEE SHEET I-2

NOTES

1. AFTER 2-INCH MILL CONTRACTOR SHALL INSPECT THE MILL AREA WITH CITY REPRESENTATIVE / ENGINEER AND IDENTIFY AREAS THAT NEED BASE REPAIRS. THE AGREED UPON DIMENSIONS SHALL BE RECORDED AS THIS WILL BE THE MEASUREMENT OF PAYMENT AND NO ADDITIONAL WORK OUTSIDE THE AGREED UPON AREA WILL BE PAID FOR.
2. ADA CURB RAMPS SHALL BE BUILT AS SHOWN ON PROJECT DETAILS. CONTRACTOR SHALL COMPLY WITH CALTRANS STANDARD DETAIL A88A AND CONTRA COSTA COUNTY DETAIL CA74. ADA CURB RAMPS IN THIS PROJECT REFER TO THE RAMP, DETECTABLE WARNING SURFACE, LANDING, WINGS, SIDEWALK REQUIRED TO CONFORM, AND RETAINING CURB IF APPLICABLE.

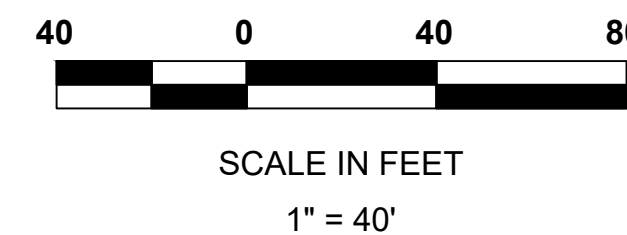

LEGEND

- INSTALL CURB RAMP CASE C, SEE CD-1 & CD-2 DETAILS 3, 4, 7, & 8
- ADJUST EXISTING FACILITY TO GRADE, SEE DETAILS 12 & 13, SHEET CD-3
- MICRO SURFACING, SEE DETAIL 1, SHEET CD-1
- POTENTIAL BASE REPAIR AREA, SEE NOTE 1 AND DETAIL 10, SHEET CD-2
- 2" MILL & OVERLAY, SEE DETAIL 11, SHEET CD-2

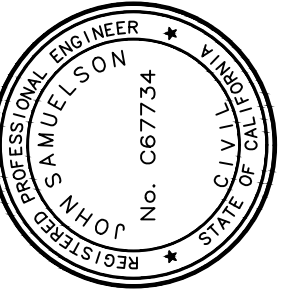

PREPARED UNDER THE DIRECTION OF:

 JOHN SAMUELSON
 P.E. C67734
 7/1/23
 Date

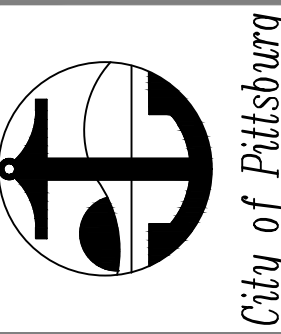

PROJECT 2241
 E LELAND ROAD PAVEMENT MAINTENANCE
 IMPROVEMENT PLANS

DATE	REV	DESCRIPTION	BY	DRAWN: SR	CHECKED: SR	REVIEWED: DJ	DATE: 7/1/23	SCALE: N/A

SHEET:
3 OF 15

SHEET NO.
I-1



E. LELAND ROAD: FROM STA. 23+00 TO STA. 34+00

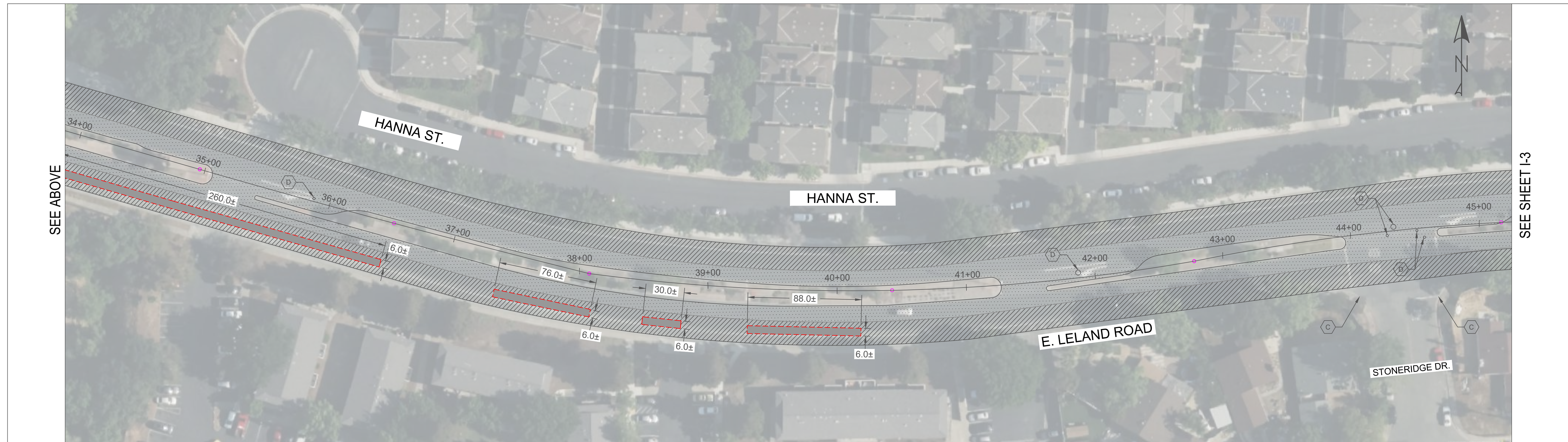

E. LELAND ROAD: FROM STA. 34+00 TO STA. 45+00

NOTES

1. AFTER 2-INCH MILL CONTRACTOR SHALL INSPECT THE MILL AREA WITH CITY REPRESENTATIVE / ENGINEER AND IDENTIFY AREAS THAT NEED BASE REPAIRS. THE AGREED UPON DIMENSIONS SHALL BE RECORDED AS THIS WILL BE THE MEASUREMENT OF PAYMENT AND NO ADDITIONAL WORK OUTSIDE THE AGREED UPON AREA WILL BE PAID FOR.
2. ADA CURB RAMPS SHALL BE BUILT AS SHOWN ON PROJECT DETAILS. CONTRACTOR SHALL COMPLY WITH CALTRANS STANDARD DETAIL A88A AND CONTRA COSTA COUNTY DETAIL CA74. ADA CURB RAMPS IN THIS PROJECT REFER TO THE RAMP, DETECTABLE WARNING SURFACE, LANDING, WINGS, SIDEWALK REQUIRED TO CONFORM, AND RETAINING CURB IF APPLICABLE.

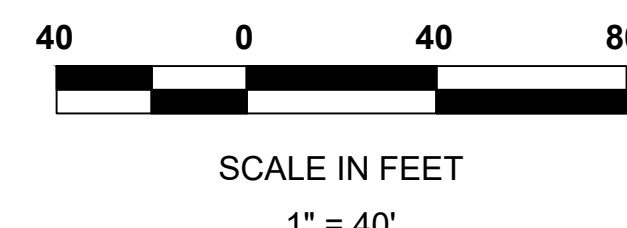

LEGEND

- INSTALL CURB RAMP CASE C, SEE CD-1 & CD-2 DETAILS 3, 4, 7, & 8
- ADJUST EXISTING FACILITY TO GRADE, SEE DETAILS 12 & 13, SHEET CD-3
- MICRO SURFACING, SEE DETAIL 1, SHEET CD-1
- POTENTIAL BASE REPAIR AREA, SEE NOTE 1 AND DETAIL 10, SHEET CD-2
- 2" MILL & OVERLAY, SEE DETAIL 11, SHEET CD-2

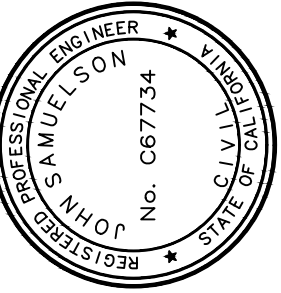

PREPARED UNDER THE DIRECTION OF:
 JOHN SAMUELSON
 No. 687734
 7/1/23
 Date

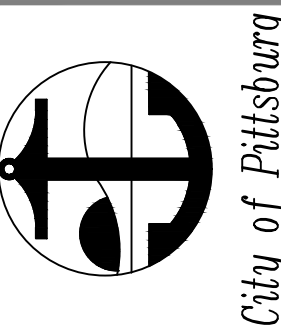

PROJECT 2241
E LELAND ROAD PAVEMENT MAINTENANCE
PROJECT NOTES

BY	DRAWN: SR
CHECKED: SR	
REVIEWED: DJ	
DATE: 7/1/23	
SCALE: N/A	

DATE	REV	DESCRIPTION

SHEET:
 4 OF 15
 SHEET NO.
1-2

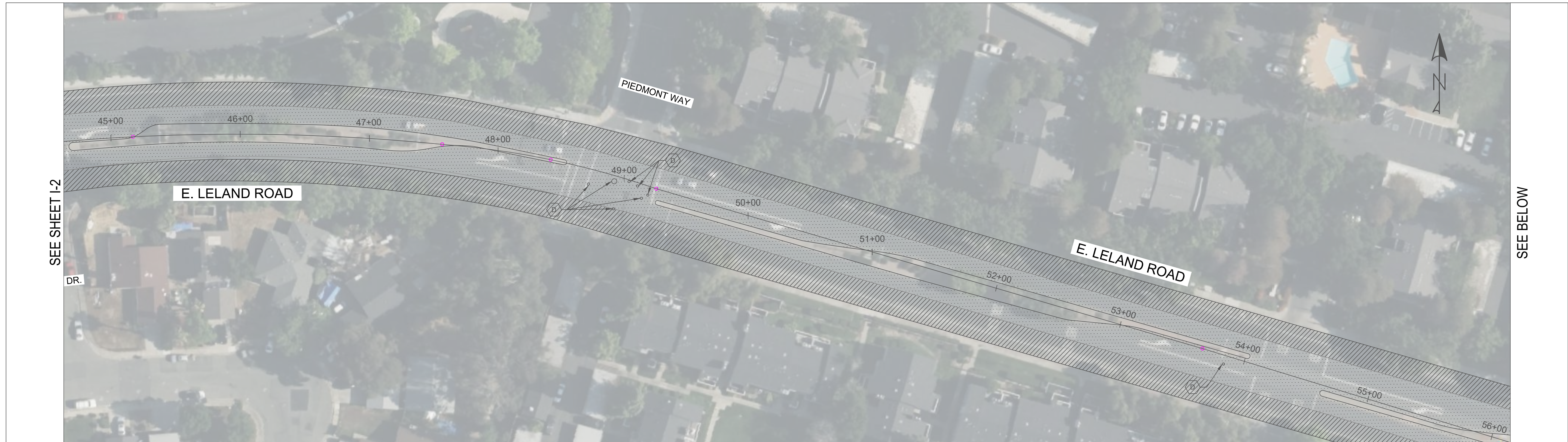

SEE SHEET I-2

SEE BELOW

E. LELAND ROAD: FROM STA. 45+00 TO STA. 56+00

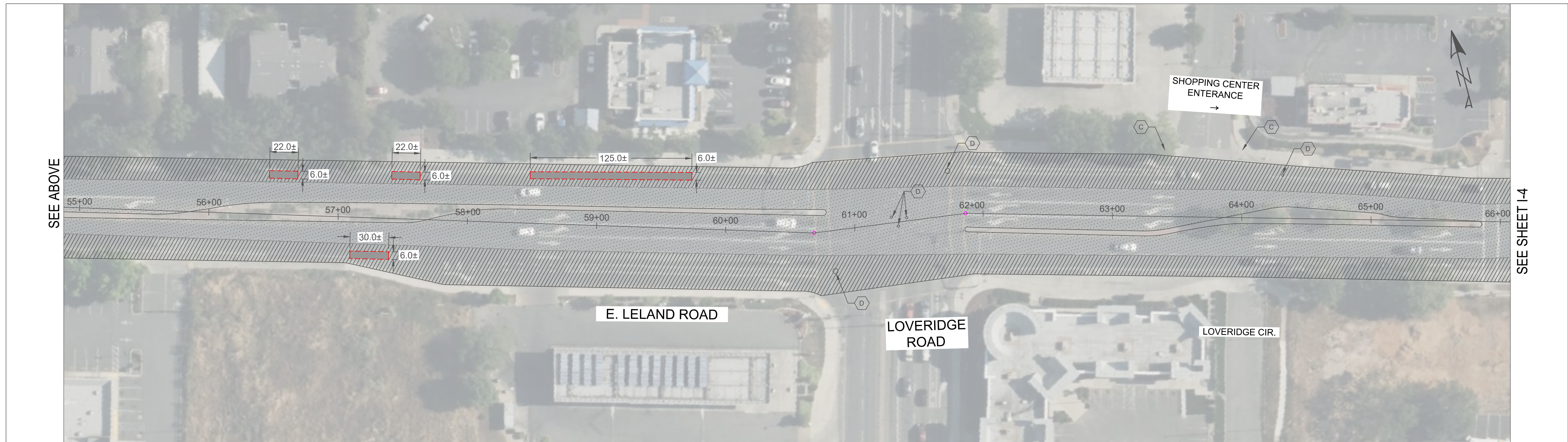

SEE ABOVE

SEE SHEET I-4

E. LELAND ROAD: FROM STA. 55+00 TO STA. 66+00

NOTES

1. AFTER 2-INCH MILL CONTRACTOR SHALL INSPECT THE MILL AREA WITH CITY REPRESENTATIVE / ENGINEER AND IDENTIFY AREAS THAT NEED BASE REPAIRS. THE AGREED UPON DIMENSIONS SHALL BE RECORDED AS THIS WILL BE THE MEASUREMENT OF PAYMENT AND NO ADDITIONAL WORK OUTSIDE THE AGREED UPON AREA WILL BE PAID FOR.
2. ADA CURB RAMPS SHALL BE BUILT AS SHOWN ON PROJECT DETAILS. CONTRACTOR SHALL COMPLY WITH CALTRANS STANDARD DETAIL A88A AND CONTRA COSTA COUNTY DETAIL CA74. ADA CURB RAMPS IN THIS PROJECT REFER TO THE RAMP, DETECTABLE WARNING SURFACE, LANDING, WINGS, SIDEWALK REQUIRED TO CONFORM, AND RETAINING CURB IF APPLICABLE.

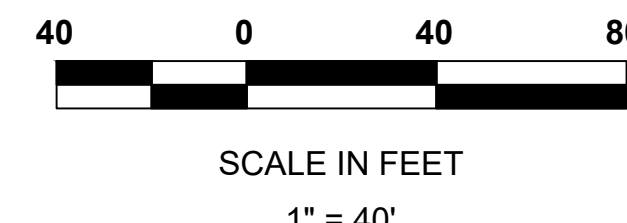

LEGEND

- INSTALL CURB RAMP CASE C, SEE CD-1 & CD-2 DETAILS 3, 4, 7, & 8
- ADJUST EXISTING FACILITY TO GRADE, SEE DETAILS 12 & 13, SHEET CD-3
- MICRO SURFACING, SEE DETAIL 1, SHEET CD-1
- POTENTIAL BASE REPAIR AREA, SEE NOTE 1 AND DETAIL 10, SHEET CD-2
- 2" MILL & OVERLAY, SEE DETAIL 11, SHEET CD-2

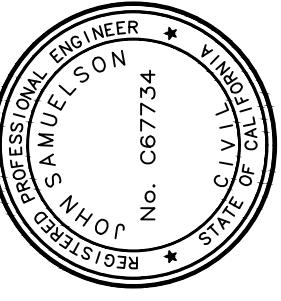

PREPARED UNDER THE DIRECTION OF:

 JOHN SAMUELSON
 P.E. C67734
 7/1/23 Date

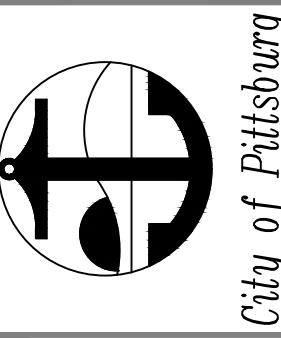

**PROJECT 2241
 E LELAND ROAD PAVEMENT MAINTENANCE
 IMPROVEMENT PLANS**

DATE	REV	DESCRIPTION	BY	SCALE
			SR	N/A



E. LELAND ROAD: FROM STA. 88+00 TO STA. 98+00



E. LELAND ROAD: FROM STA. 98+00 TO STA. 105+15

NOTES

1. AFTER 2-INCH MILL CONTRACTOR SHALL INSPECT THE MILL AREA WITH CITY REPRESENTATIVE / ENGINEER AND IDENTIFY AREAS THAT NEED BASE REPAIRS. THE AGREED UPON DIMENSIONS SHALL BE RECORDED AS THIS WILL BE THE MEASUREMENT OF PAYMENT AND NO ADDITIONAL WORK OUTSIDE THE AGREED UPON AREA WILL BE PAID FOR.
2. ADA CURB RAMPS SHALL BE BUILT AS SHOWN ON PROJECT DETAILS. CONTRACTOR SHALL COMPLY WITH CALTRANS STANDARD DETAIL A88A AND CONTRA COSTA COUNTY DETAIL CA74. ADA CURB RAMPS IN THIS PROJECT REFER TO THE RAMP, DETECTABLE WARNING SURFACE, LANDING, WINGS, SIDEWALK REQUIRED TO CONFORM, AND RETAINING CURB IF APPLICABLE.

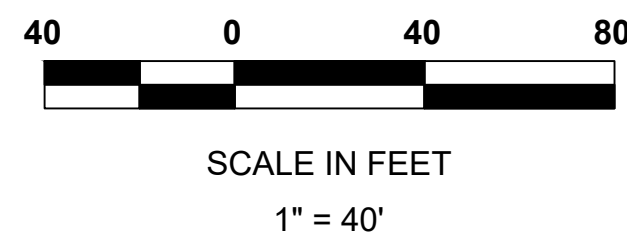

LEGEND

- (A) INSTALL CURB RAMP CASE A, SEE DETAILS 5, 7, AND 8
- (B) INSTALL CURB RAMP CASE B, SEE DETAILS 6, 7, AND 8
- (D) ADJUST EXISTING FACILITY TO GRADE
- (R) REMOVE AND REPLACE TRAFFIC SIGNAL BOX
- (X) DEMO MEDIAN AND INSTALL 7 LF OF 6" CONCRETE CURB
- [Dotted pattern] MICRO SURFACING, SEE DETAIL 1, SHEET CD-1
- [Red hatched pattern] POTENTIAL BASE REPAIR AREA, SEE NOTE 1 AND DETAIL 10, SHEET CD-2
- [Diagonal hatched pattern] 2" MILL & OVERLAY, SEE DETAIL 11, SHEET CD-2
- [Cross-hatched pattern] DEMO MEDIAN AND REPLACE 6" CURB, SEE DETAIL 9, SHEET CD-2

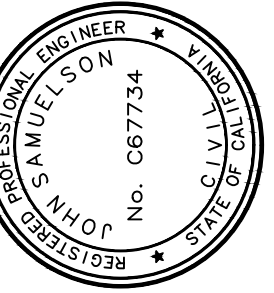

PREPARED UNDER THE DIRECTION OF:

JOHN SAMUELSON
No. 067734
7/1/23
DATE

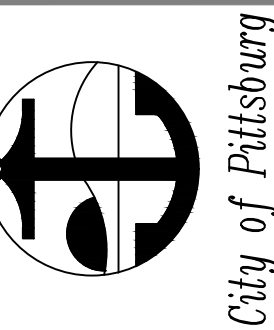

PROJECT 2241
E LELAND ROAD PAVEMENT MAINTENANCE
IMPROVEMENT PLANS

BY	SR
CHECKED	SR
REVIEWED	DJ
DATE	7/1/23
SCALE	N/A

DATE	REV	DESCRIPTION

SHEET: 7 OF 15

SHEET NO. **I-5**

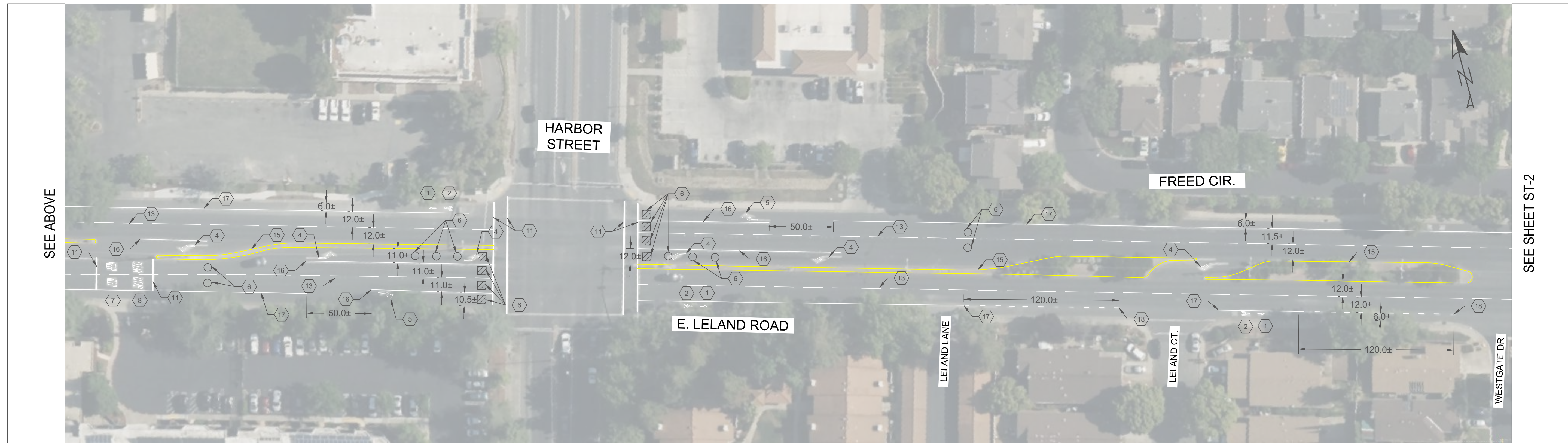
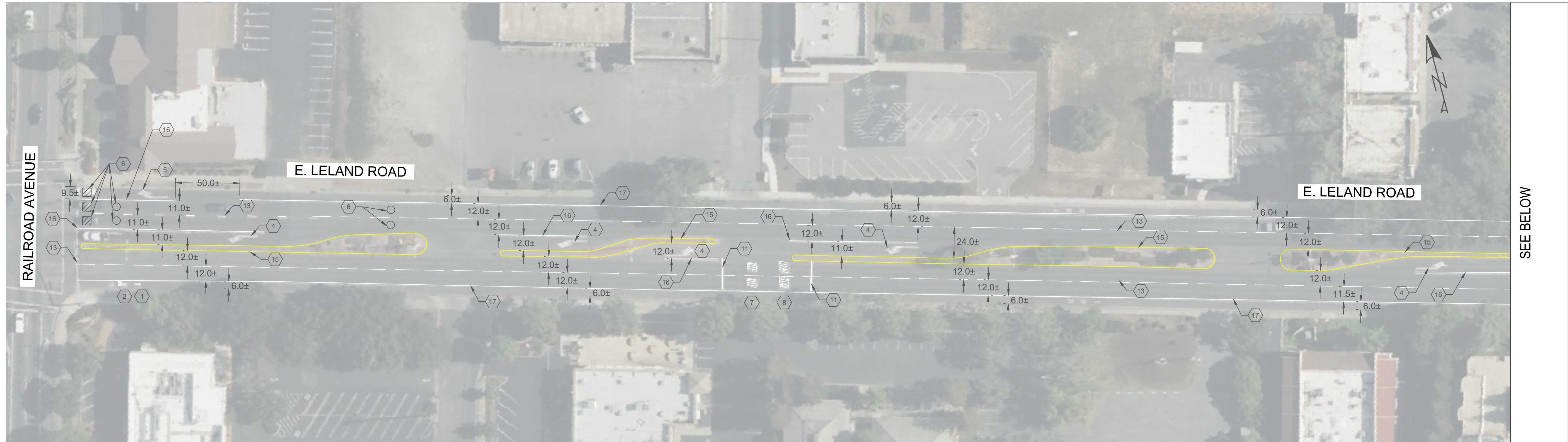

NOTES

1. BLUE RAISED REFLECTIVE MARKERS TO BE PLACED ON ROAD TO MARK FIRE HYDRANTS. PLACE PER CA MUTCD SECTION 3B.11.
2. PAVEMENT MARKING LETTERS AND SYMBOLS SHALL BE PLACED PER CALTRANS PLANS A24.
3. BIKE LANE LOOP DETECTORS SHALL BE CALTRANS TYPE C. MOTOR VEHICLE LANE LOOP DETECTORS SHALL BE TYPE E & D. TYPE D SHALL ONLY BE USED ON DETECTORS ADJACENT TO A CROSSWALK.

KEYNOTES

- | | | |
|---|---|-------------------------------|
| ① INSTALL CALTRANS BIKE LANE ARROW | ⑦ INSTALL CALTRANS PAVEMENT MARKING "KEEP" | ⑬ INSTALL CALTRANS DETAIL 9 |
| ② INSTALL CALTRANS BIKE LANE SYMBOL WITH PERSON | ⑧ INSTALL CALTRANS PAVEMENT MARKING "CLEAR" | ⑭ NOT USED |
| ③ INSTALL CALTRANS BICYCLE LOOP DETECTOR SYMBOL | ⑨ NOT USED | ⑮ INSTALL CALTRANS DETAIL 24 |
| ④ INSTALL CALTRANS TYPE IV LEFT ARROW | ⑩ NOT USED | ⑯ INSTALL CALTRANS DETAIL 38 |
| ⑤ INSTALL CALTRANS TYPE IV RIGHT ARROW | ⑪ INSTALL 12" WHITE CROSSWALK / LIMIT LINE | ⑰ INSTALL CALTRANS DETAIL 39 |
| ⑥ INSTALL TRAFFIC SIGNAL DETECTOR LOOPS, SEE NOTE 3 | ⑫ NOT USED | ⑱ INSTALL CALTRANS DETAIL 39A |



SCALE IN FEET
1" = 40'

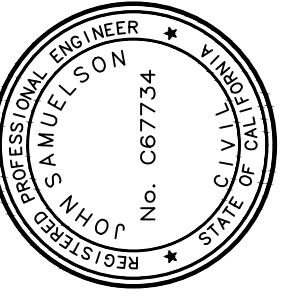

PREPARED UNDER THE DIRECTION OF:
JOHN SAMUELSON
PCE 067734
Date: 7/1/23

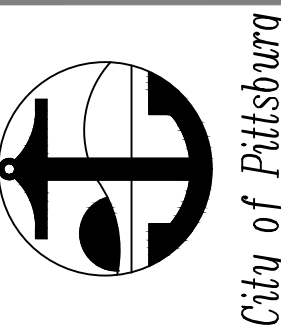

PROJECT 2241
E LELAND ROAD PAVEMENT MAINTENANCE
STRIPING PLANS

BY	DRAWN: SR
CHECKED: SR	
REVIEWED: DJ	
DATE: 7/1/23	
SCALE: N/A	

DATE	REV	DESCRIPTION

SHEET:
8 OF 15

SHEET NO.
ST-1

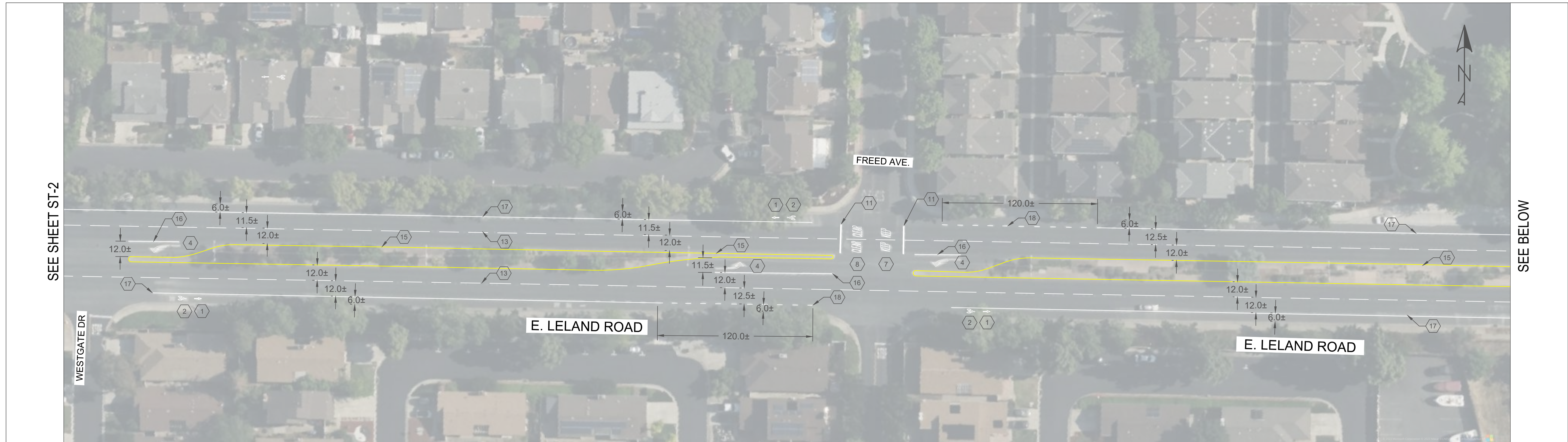

NOTES

1. BLUE RAISED REFLECTIVE MARKERS TO BE PLACED ON ROAD TO MARK FIRE HYDRANTS. PLACE PER CA MUTCD SECTION 3B.11.
2. PAVEMENT MARKING LETTERS AND SYMBOLS SHALL BE PLACED PER CALTRANS PLANS A24.
3. BIKE LANE LOOP DETECTORS SHALL BE CALTRANS TYPE C. MOTOR VEHICLE LANE LOOP DETECTORS SHALL BE TYPE E & D. TYPE D SHALL ONLY BE USED ON DETECTORS ADJACENT TO A CROSSWALK.

KEYNOTES

- | | | |
|---|---|-------------------------------|
| ① INSTALL CALTRANS BIKE LANE ARROW | ⑦ INSTALL CALTRANS PAVEMENT MARKING "KEEP" | ⑬ INSTALL CALTRANS DETAIL 9 |
| ② INSTALL CALTRANS BIKE LANE SYMBOL WITH PERSON | ⑧ INSTALL CALTRANS PAVEMENT MARKING "CLEAR" | ⑭ NOT USED |
| ③ INSTALL CALTRANS BICYCLE LOOP DETECTOR SYMBOL | ⑨ NOT USED | ⑮ INSTALL CALTRANS DETAIL 24 |
| ④ INSTALL CALTRANS TYPE IV LEFT ARROW | ⑩ NOT USED | ⑯ INSTALL CALTRANS DETAIL 38 |
| ⑤ NOT USED | ⑪ INSTALL 12" WHITE CROSSWALK / LIMIT LINE | ⑰ INSTALL CALTRANS DETAIL 39 |
| ⑥ INSTALL TRAFFIC SIGNAL DETECTOR LOOPS, SEE NOTE 3 | ⑫ NOT USED | ⑱ INSTALL CALTRANS DETAIL 39A |

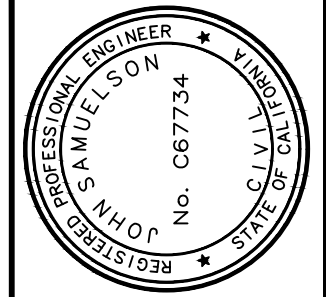
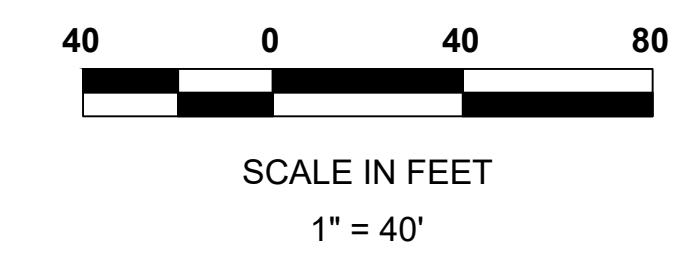

PREPARED UNDER THE DIRECTION OF:
 JOHN SAMUELSON
 REG. CIVIL ENGINEER
 No. 067734
 7/1/23 Date

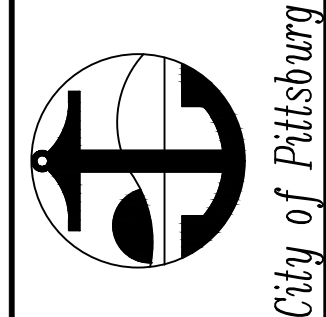

**PROJECT 2241
 E LELAND ROAD PAVEMENT MAINTENANCE
 STRIPING PLANS**

DATE	REV	DESCRIPTION	BY	DRAWN: SR	CHECKED: SR	REVIEWED: DJ	DATE: 7/1/23	SCALE: N/A

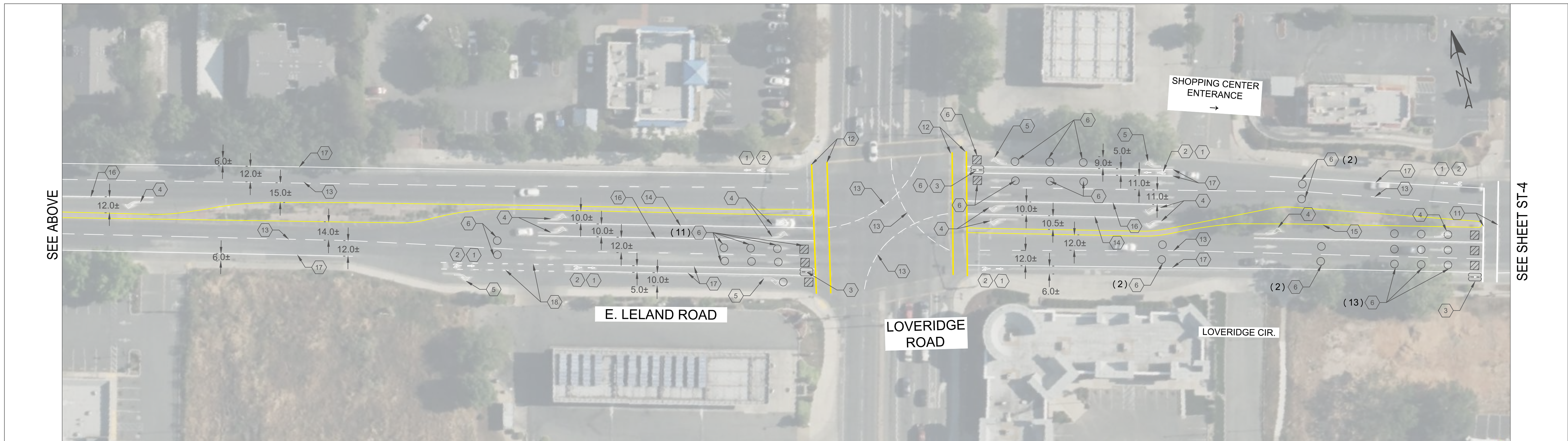
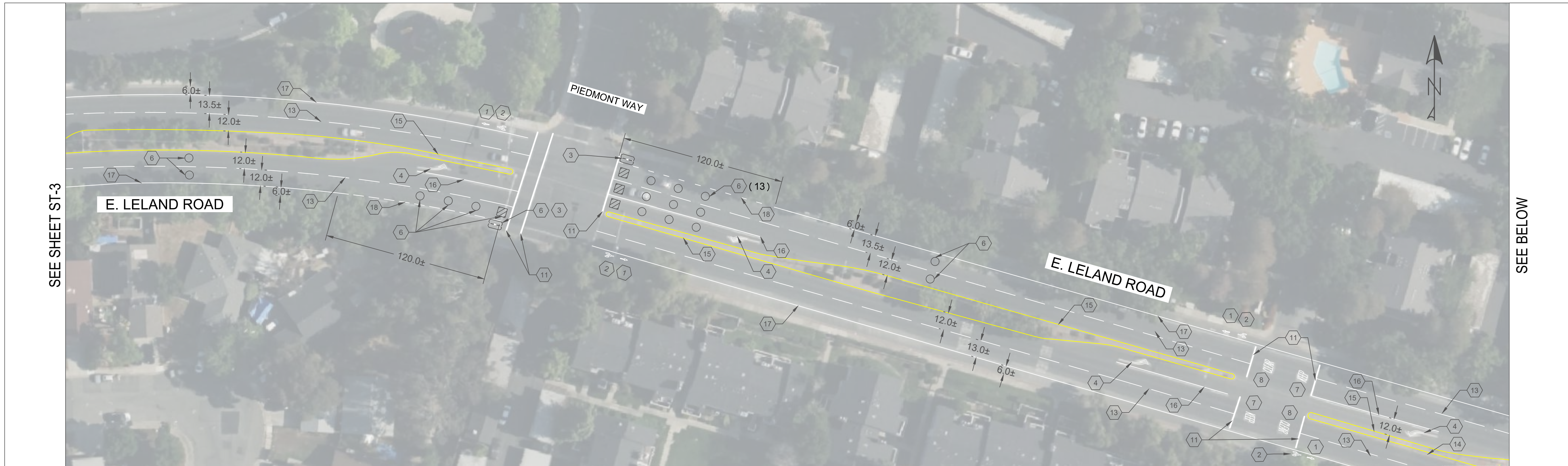

NOTES

1. BLUE RAISED REFLECTIVE MARKERS TO BE PLACED ON ROAD TO MARK FIRE HYDRANTS. PLACE PER CA MUTCD SECTION 3B.11.
2. PAVEMENT MARKING LETTERS AND SYMBOLS SHALL BE PLACED PER CALTRANS PLANS A24.
3. BIKE LANE LOOP DETECTORS SHALL BE CALTRANS TYPE C. MOTOR VEHICLE LANE LOOP DETECTORS SHALL BE TYPE E & D. TYPE D SHALL ONLY BE USED ON DETECTORS ADJACENT TO A CROSSWALK.

KEYNOTES

- | | | |
|--|---|---|
| <ul style="list-style-type: none"> ① INSTALL CALTRANS BIKE LANE ARROW ② INSTALL CALTRANS BIKE LANE SYMBOL WITH PERSON ③ INSTALL CALTRANS BICYCLE LOOP DETECTOR SYMBOL ④ INSTALL CALTRANS TYPE IV LEFT ARROW ⑤ INSTALL CALTRANS TYPE IV RIGHT ARROW ⑥ INSTALL TRAFFIC SIGNAL DETECTOR LOOPS, SEE NOTE 3 | <ul style="list-style-type: none"> ⑦ INSTALL CALTRANS PAVEMENT MARKING "KEEP" ⑧ INSTALL CALTRANS PAVEMENT MARKING "CLEAR" ⑨ INSTALL CALTRANS PAVEMENT MARKING "SIGNAL" ⑩ INSTALL CALTRANS PAVEMENT MARKING "AHEAD" ⑪ INSTALL 12" WHITE CROSSWALK / LIMIT LINE ⑫ INSTALL 12" YELLOW CROSSWALK / LIMIT LINE | <ul style="list-style-type: none"> ⑬ INSTALL CALTRANS DETAIL 9 ⑭ INSTALL CALTRANS DETAIL 38A ⑮ INSTALL CALTRANS DETAIL 26 ⑯ INSTALL CALTRANS DETAIL 38 ⑰ INSTALL CALTRANS DETAIL 39 ⑱ INSTALL CALTRANS DETAIL 39A |
|--|---|---|

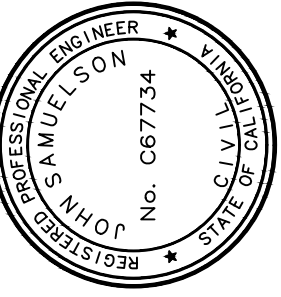
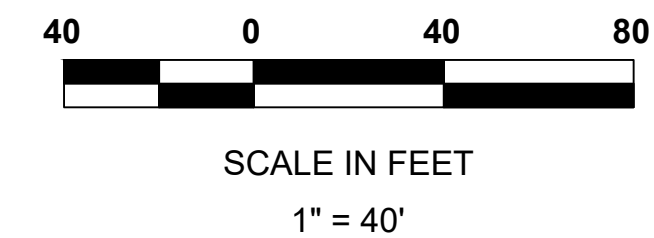

PREPARED UNDER THE DIRECTION OF:
 JOHN SAMUELSON
 RCE 08734
 7/1/23
 Date

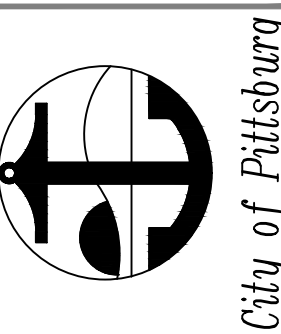

**PROJECT 2241
 E LELAND ROAD PAVEMENT MAINTENANCE
 STRIPING PLANS**

BY: DRAWN: SR
 CHECKED: SR
 REVIEWED: DJ
 DATE: 7/1/23
 SCALE: N/A

DATE	REV	DESCRIPTION

SHEET:
 10 OF 15

SHEET NO.
ST-3

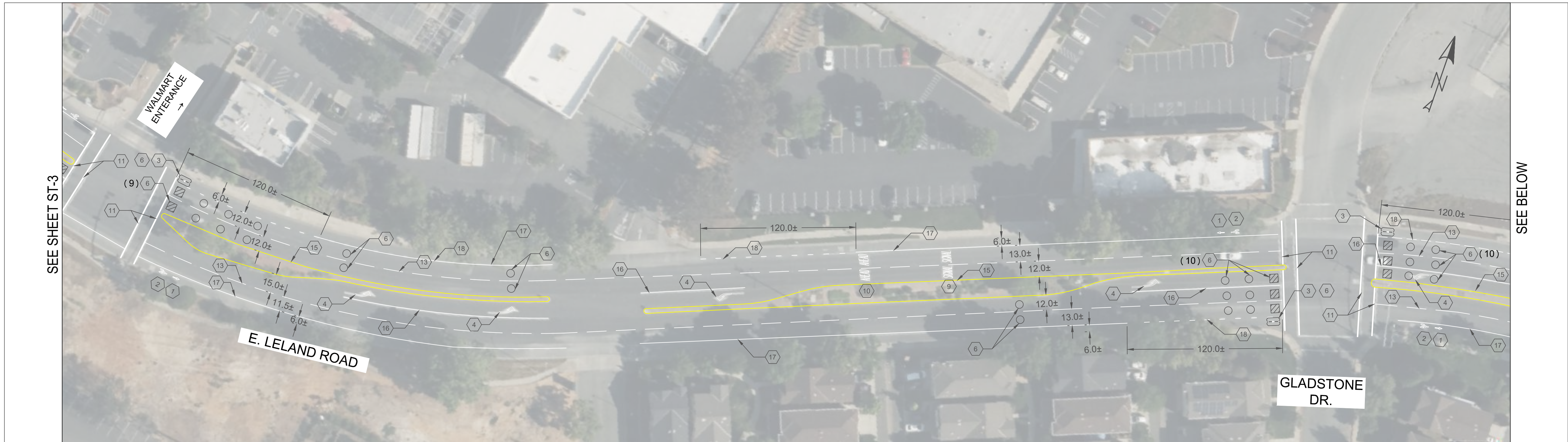

SEE SHEET ST-3

SEE BELOW

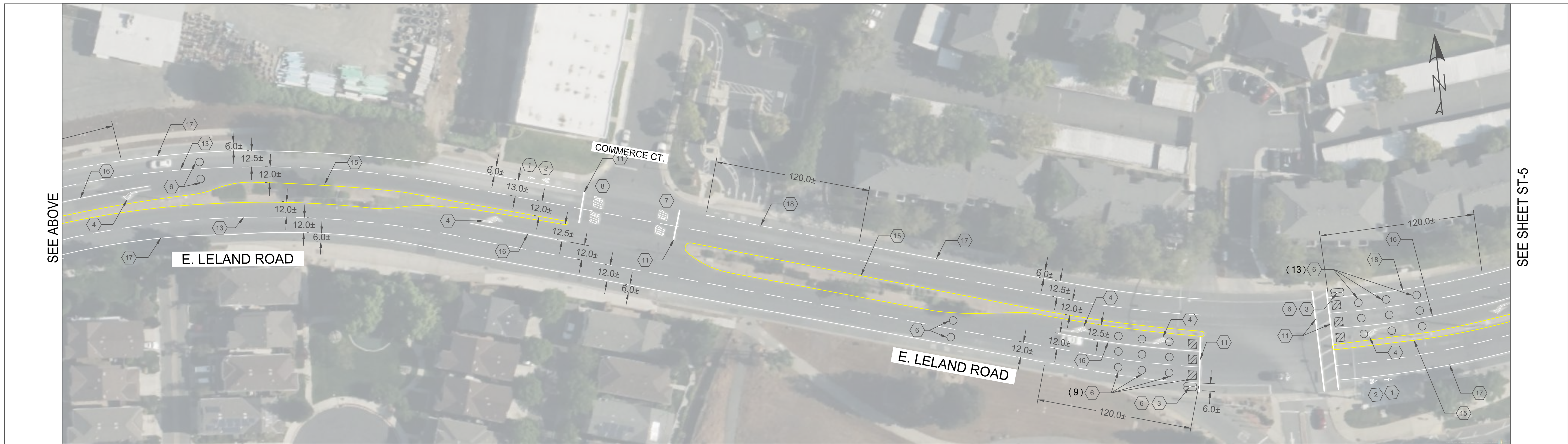

SEE ABOVE

SEE SHEET ST-5

NOTES

1. BLUE RAISED REFLECTIVE MARKERS TO BE PLACED ON ROAD TO MARK FIRE HYDRANTS. PLACE PER CA MUTCD SECTION 3B.11.
2. PAVEMENT MARKING LETTERS AND SYMBOLS SHALL BE PLACED PER CALTRANS PLANS A24.
3. BIKE LANE LOOP DETECTORS SHALL BE CALTRANS TYPE C. MOTOR VEHICLE LANE LOOP DETECTORS SHALL BE TYPE E & D. TYPE D SHALL ONLY BE USED ON DETECTORS ADJACENT TO A CROSSWALK.

KEYNOTES

- | | | |
|---|--|-------------------------------|
| ① INSTALL CALTRANS BIKE LANE ARROW | ⑦ INSTALL CALTRANS PAVEMENT MARKING "KEEP" | ⑬ INSTALL CALTRANS DETAIL 9 |
| ② INSTALL CALTRANS BIKE LANE SYMBOL WITH PERSON | ⑧ INSTALL CALTRANS PAVEMENT MARKING "CLEAR" | ⑭ NOT USED |
| ③ INSTALL CALTRANS BICYCLE LOOP DETECTOR SYMBOL | ⑨ INSTALL CALTRANS PAVEMENT MARKING "SIGNAL" | ⑮ INSTALL CALTRANS DETAIL 26 |
| ④ INSTALL CALTRANS TYPE IV LEFT ARROW | ⑩ INSTALL CALTRANS PAVEMENT MARKING "AHEAD" | ⑯ INSTALL CALTRANS DETAIL 38 |
| ⑤ INSTALL CALTRANS TYPE IV RIGHT ARROW | ⑪ INSTALL 12" WHITE CROSSWALK / LIMIT LINE | ⑰ INSTALL CALTRANS DETAIL 39 |
| ⑥ INSTALL TRAFFIC SIGNAL DETECTOR LOOPS, SEE NOTE 3 | ⑫ NOT USED | ⑱ INSTALL CALTRANS DETAIL 39A |



SCALE IN FEET
1" = 40'

ORIGINAL PAGE SIZE: 22"X34"

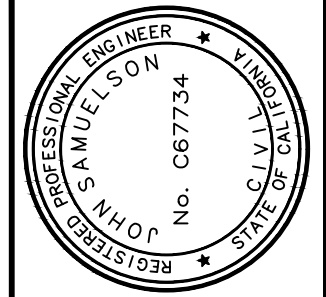

PREPARED UNDER THE DIRECTION OF:
JOHN SAMUELSON
RCE 08734
7/1/23
Date

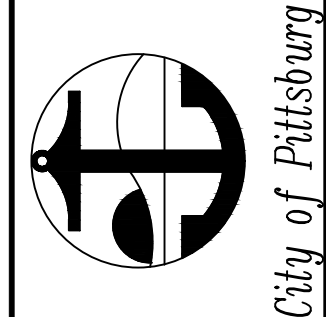

PROJECT 2241
E LELAND ROAD PAVEMENT MAINTENANCE
STRIPING PLANS

BY	DRAWN: SR
CHECKED: SR	
REVIEWED: DJ	
DATE: 7/1/23	
SCALE: N/A	

DATE	REV	DESCRIPTION

SHEET:
11 OF 15

SHEET NO.
ST-4

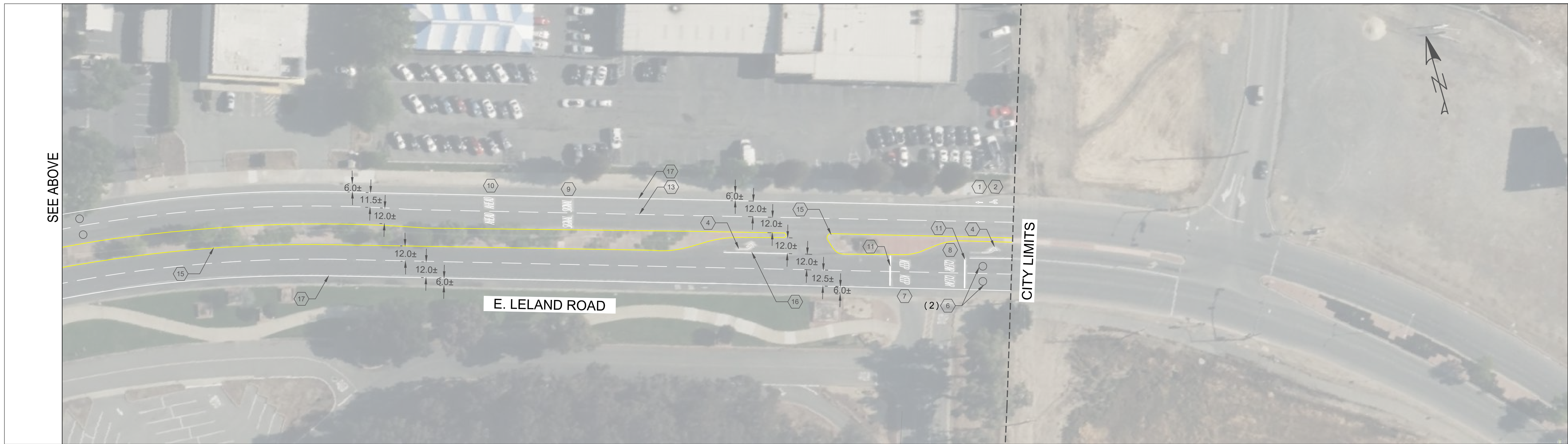

NOTES

1. BLUE RAISED REFLECTIVE MARKERS TO BE PLACED ON ROAD TO MARK FIRE HYDRANTS. PLACE PER CA MUTCD SECTION 3B.11.
2. PAVEMENT MARKING LETTERS AND SYMBOLS SHALL BE PLACED PER CALTRANS PLANS A24.
3. BIKE LANE LOOP DETECTORS SHALL BE CALTRANS TYPE C. MOTOR VEHICLE LANE LOOP DETECTORS SHALL BE TYPE E & D. TYPE D SHALL ONLY BE USED ON DETECTORS ADJACENT TO A CROSSWALK.

KEYNOTES

- | | | |
|---|--|-------------------------------|
| ① INSTALL CALTRANS BIKE LANE ARROW | ⑦ INSTALL CALTRANS PAVEMENT MARKING "KEEP" | ⑬ INSTALL CALTRANS DETAIL 9 |
| ② INSTALL CALTRANS BIKE LANE SYMBOL WITH PERSON | ⑧ INSTALL CALTRANS PAVEMENT MARKING "CLEAR" | ⑭ NOT USED |
| ③ INSTALL CALTRANS BICYCLE LOOP DETECTOR SYMBOL | ⑨ INSTALL CALTRANS PAVEMENT MARKING "SIGNAL" | ⑮ INSTALL CALTRANS DETAIL 26 |
| ④ INSTALL CALTRANS TYPE IV LEFT ARROW | ⑩ INSTALL CALTRANS PAVEMENT MARKING "AHEAD" | ⑯ INSTALL CALTRANS DETAIL 38 |
| ⑤ INSTALL CALTRANS TYPE IV RIGHT ARROW | ⑪ INSTALL 12" WHITE CROSSWALK / LIMIT LINE | ⑰ INSTALL CALTRANS DETAIL 39 |
| ⑥ INSTALL TRAFFIC SIGNAL DETECTOR LOOPS, SEE NOTE 3 | ⑫ NOT USED | ⑱ INSTALL CALTRANS DETAIL 39A |



SCALE IN FEET
1" = 40'

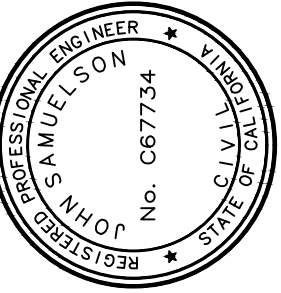

PREPARED UNDER THE DIRECTION OF:
JOHN SAMUELSON
RCE 087734
7/1/23
Date

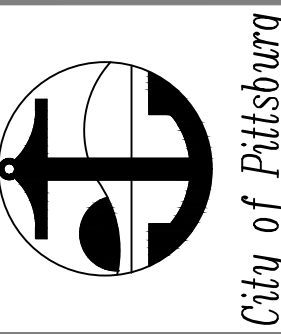

PROJECT 2241
E LELAND ROAD PAVEMENT MAINTENANCE
STRIPING PLANS

BY: DRAWN: SR
CHECKED: SR
REVIEWED: DJ
DATE: 7/1/23
SCALE: N/A

DATE	REV	DESCRIPTION

SHEET:
12 OF 15

SHEET NO.
ST-5

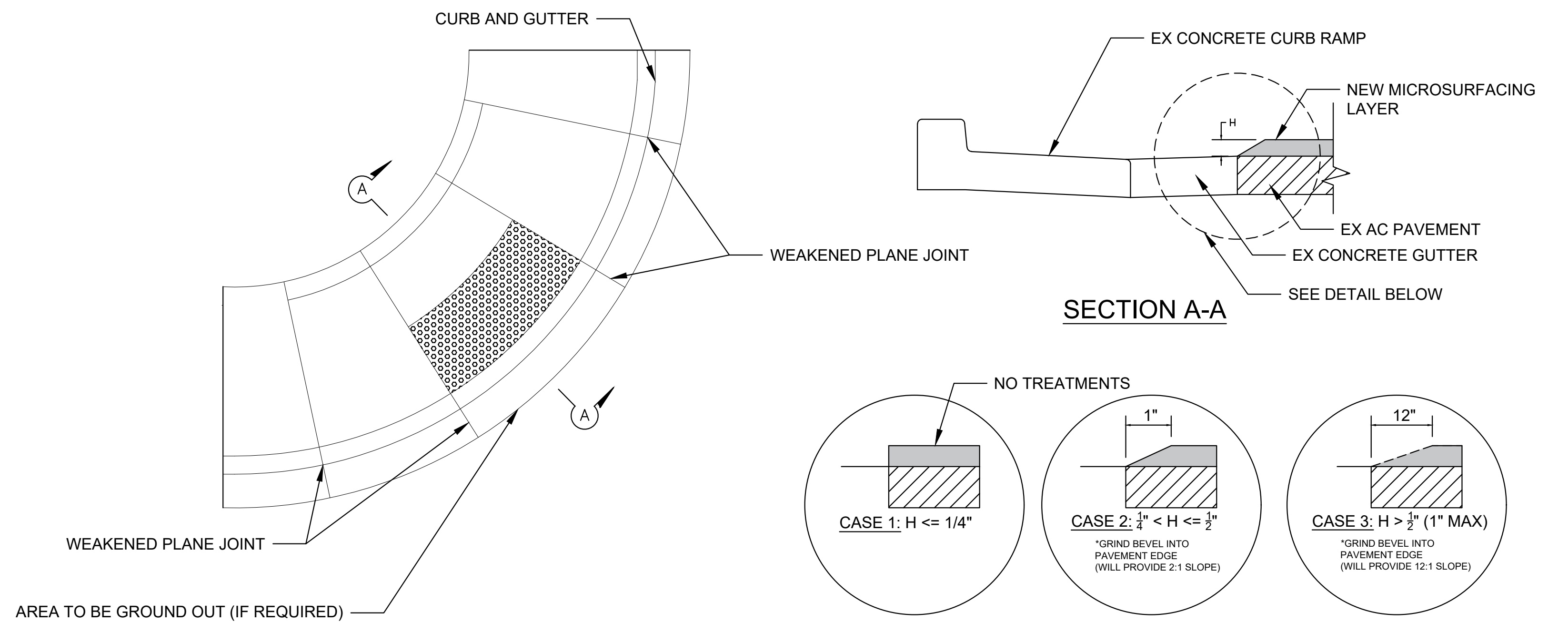

SECTION A-A

NOTE: HEIGHT "H" IS TAKEN AS THE AVERAGE PROTRUSION OF PAVEMENT MATERIAL AT LIP OF GUTTER.

DETAIL 1
NOT TO SCALE

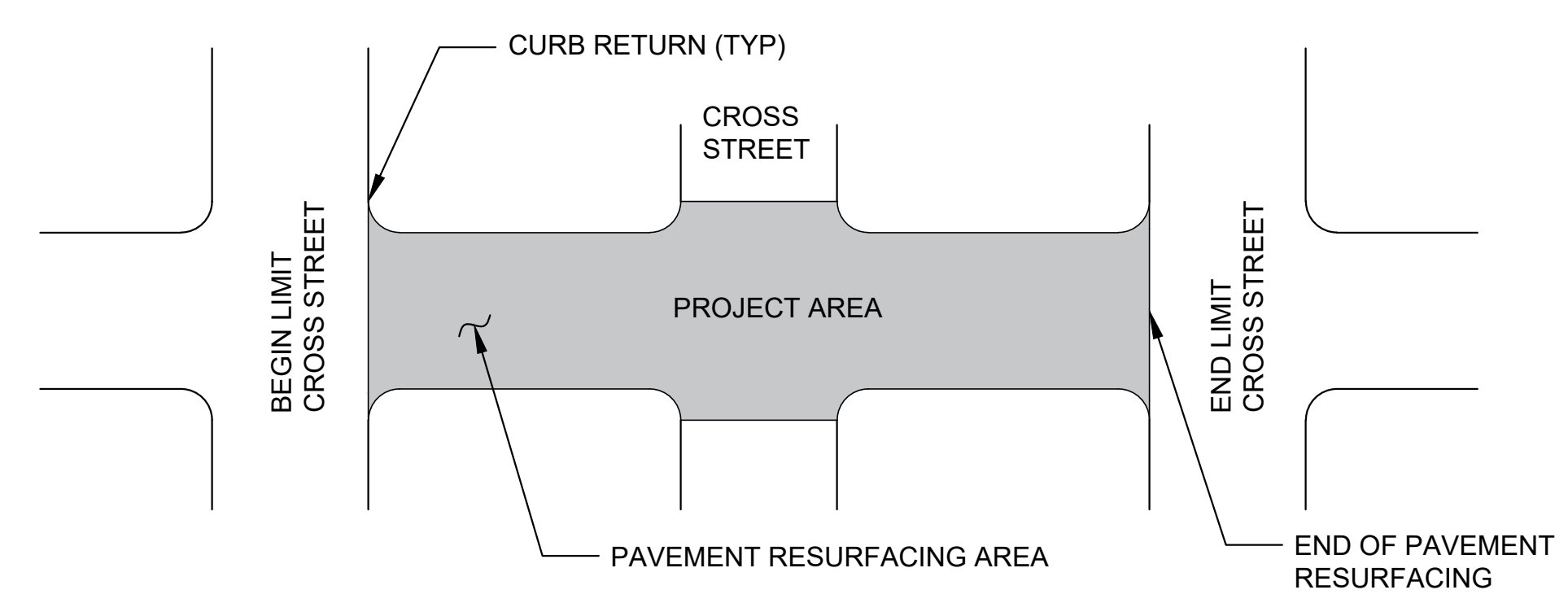

DETAIL 2 - PAVEMENT RESURFACING LIMITS
NOT TO SCALE

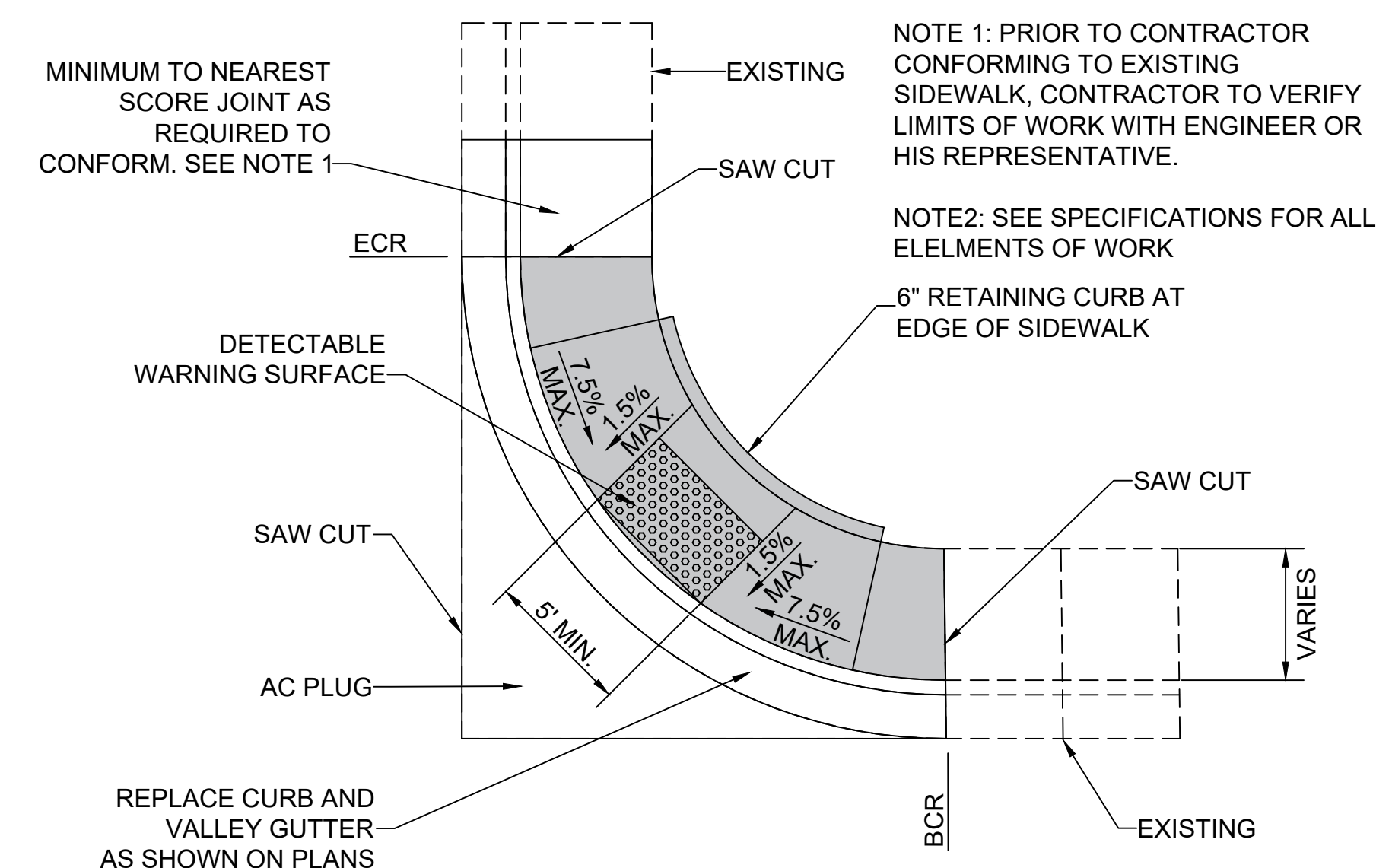

DETAIL 3 - CASE C RAMP

NOT TO SCALE, SEE IMPROVEMENT PLANS FOR LOCATIONS

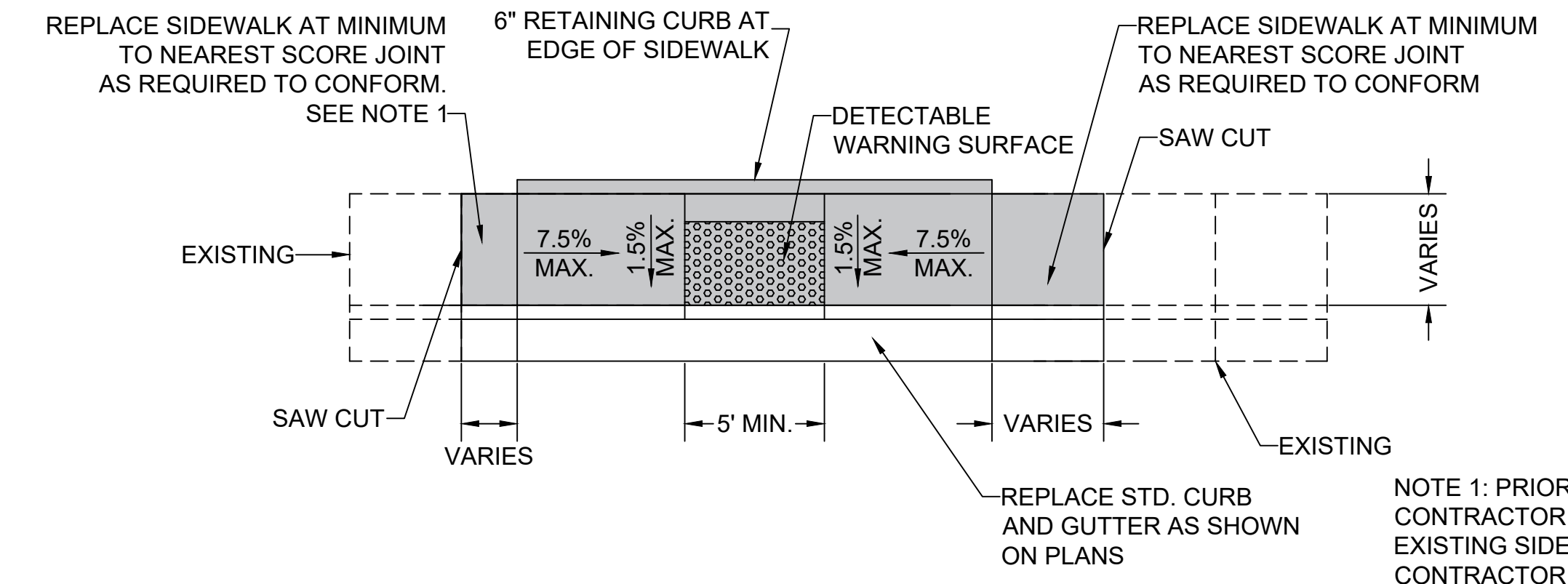

DETAIL 4 - SIDE WALK & CASE C RAMP
NOT TO SCALE, SEE IMPROVEMENT PLANS FOR LOCATIONS

NOTE 1: PRIOR TO CONTRACTOR CONFORMING TO EXISTING SIDEWALK, CONTRACTOR TO VERIFY LIMITS OF WORK WITH ENGINEER OR HIS REPRESENTATIVE.
NOTE 2: SEE SPECIFICATIONS FOR ALL ELEMETS OF WORK

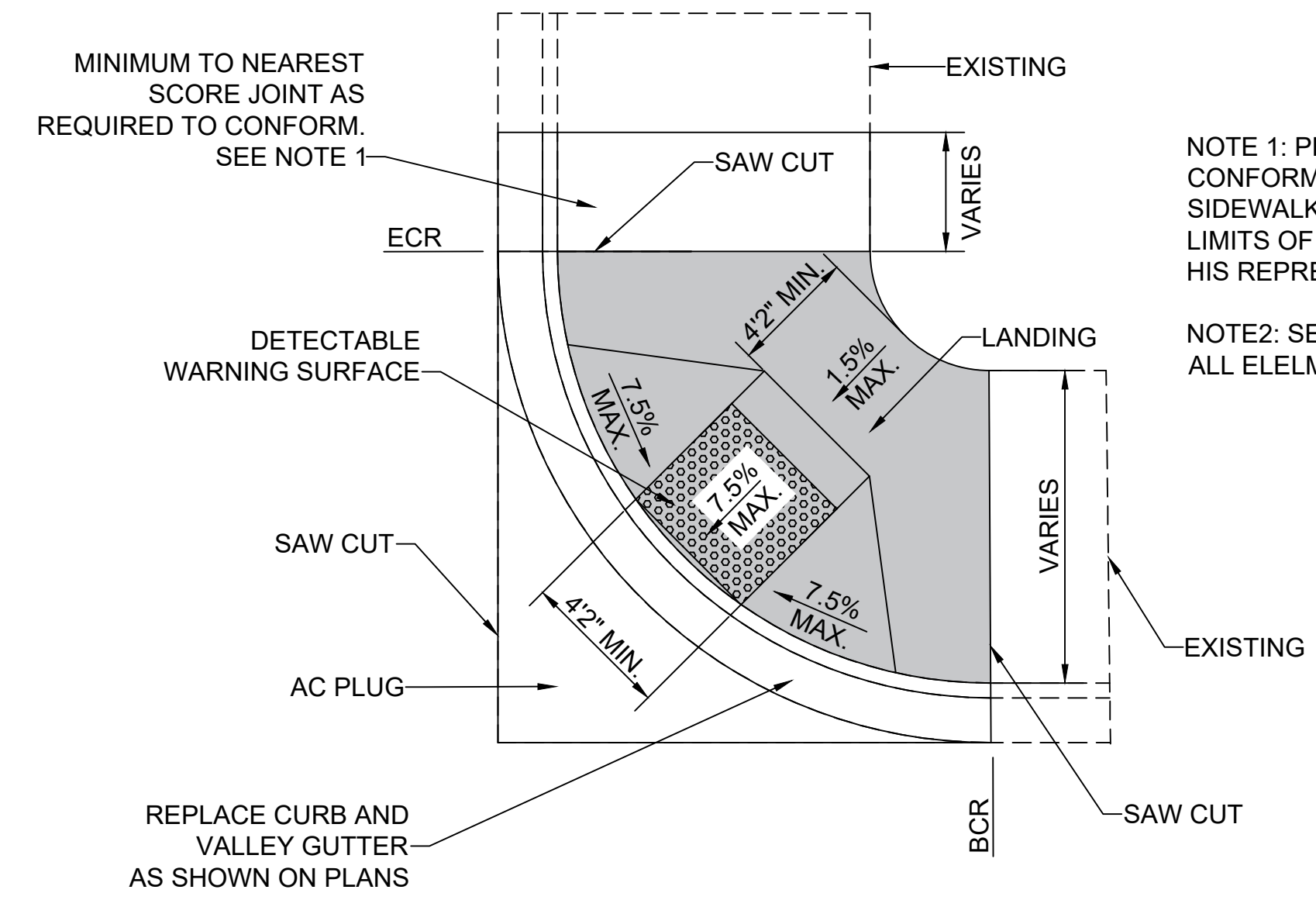

DETAIL 5 - CASE A RAMP

NOT TO SCALE, SEE IMPROVEMENT PLANS FOR LOCATIONS

NOTE 1: PRIOR TO CONTRACTOR CONFORMING TO EXISTING SIDEWALK, CONTRACTOR TO VERIFY LIMITS OF WORK WITH ENGINEER OR HIS REPRESENTATIVE.
NOTE 2: SEE SPECIFICATIONS FOR ALL ELEMETS OF WORK.

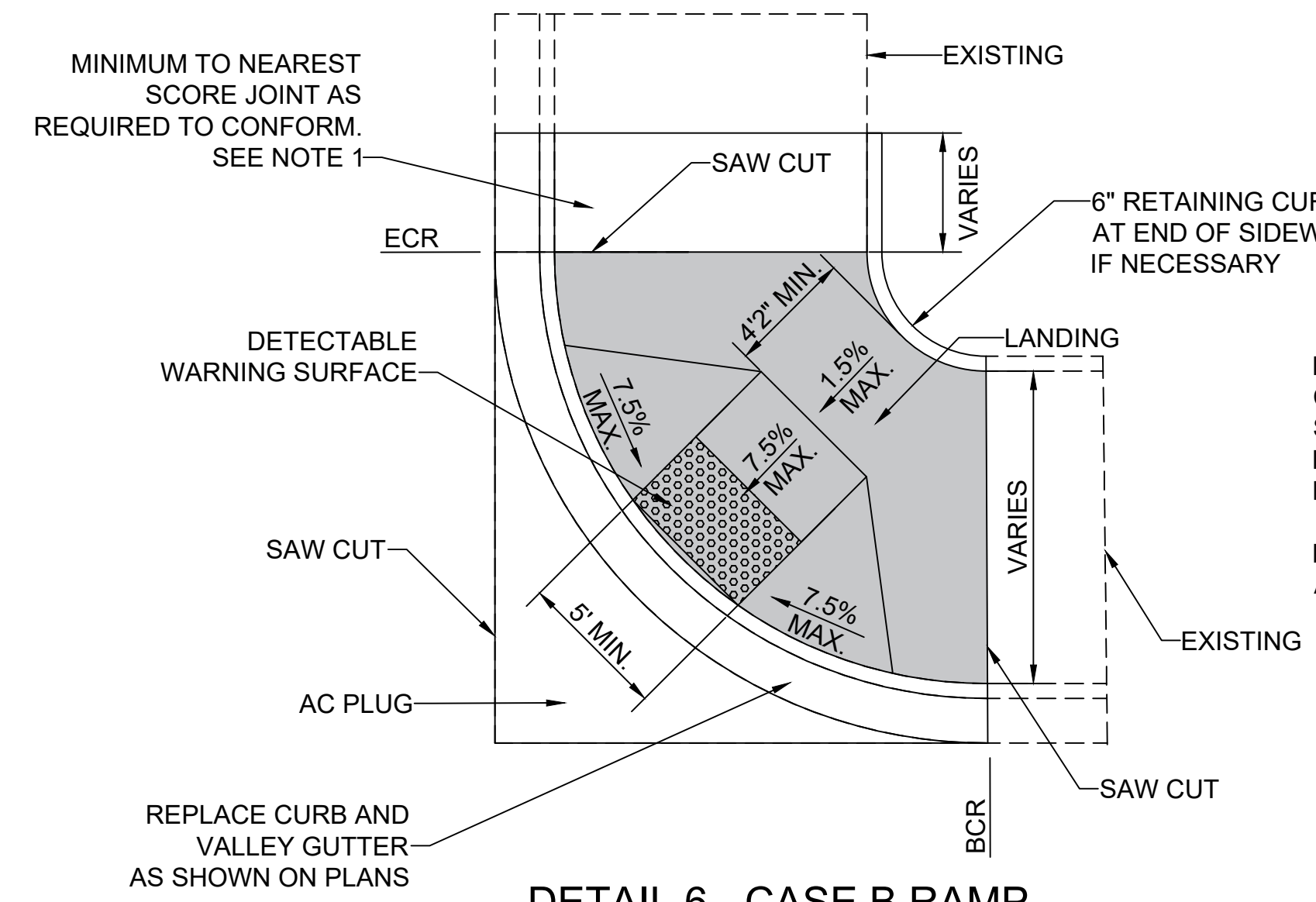

DETAIL 6 - CASE B RAMP

NOT TO SCALE, SEE IMPROVEMENT PLANS FOR LOCATIONS

NOTE 1: PRIOR TO CONTRACTOR CONFORMING TO EXISTING SIDEWALK, CONTRACTOR TO VERIFY LIMITS OF WORK WITH ENGINEER OR HIS REPRESENTATIVE.
NOTE 2: SEE SPECIFICATIONS FOR ALL ELEMETS OF WORK.

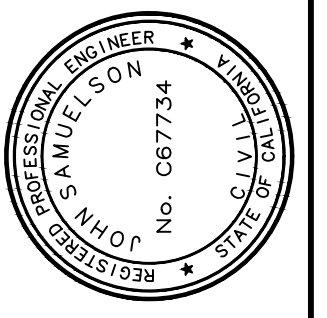

PREPARED UNDER THE DIRECTION OF:
DATE: 7/12/23
JOHN SAMUELSON
RCE 067734

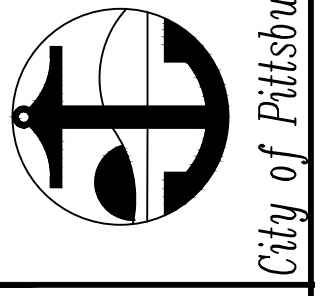

PROJECT 2241
E LELAND ROAD PAVEMENT MAINTENANCE
PROJECT DETAILS

BY	DRAWN: SR	CHECKED: SR	REVIEWED: DJ	DATE: 7/12/23	SCALE: N/A
DESCRIPTION					
REV					

SHEET:
13 OF 15
SHEET NO.
CD-1

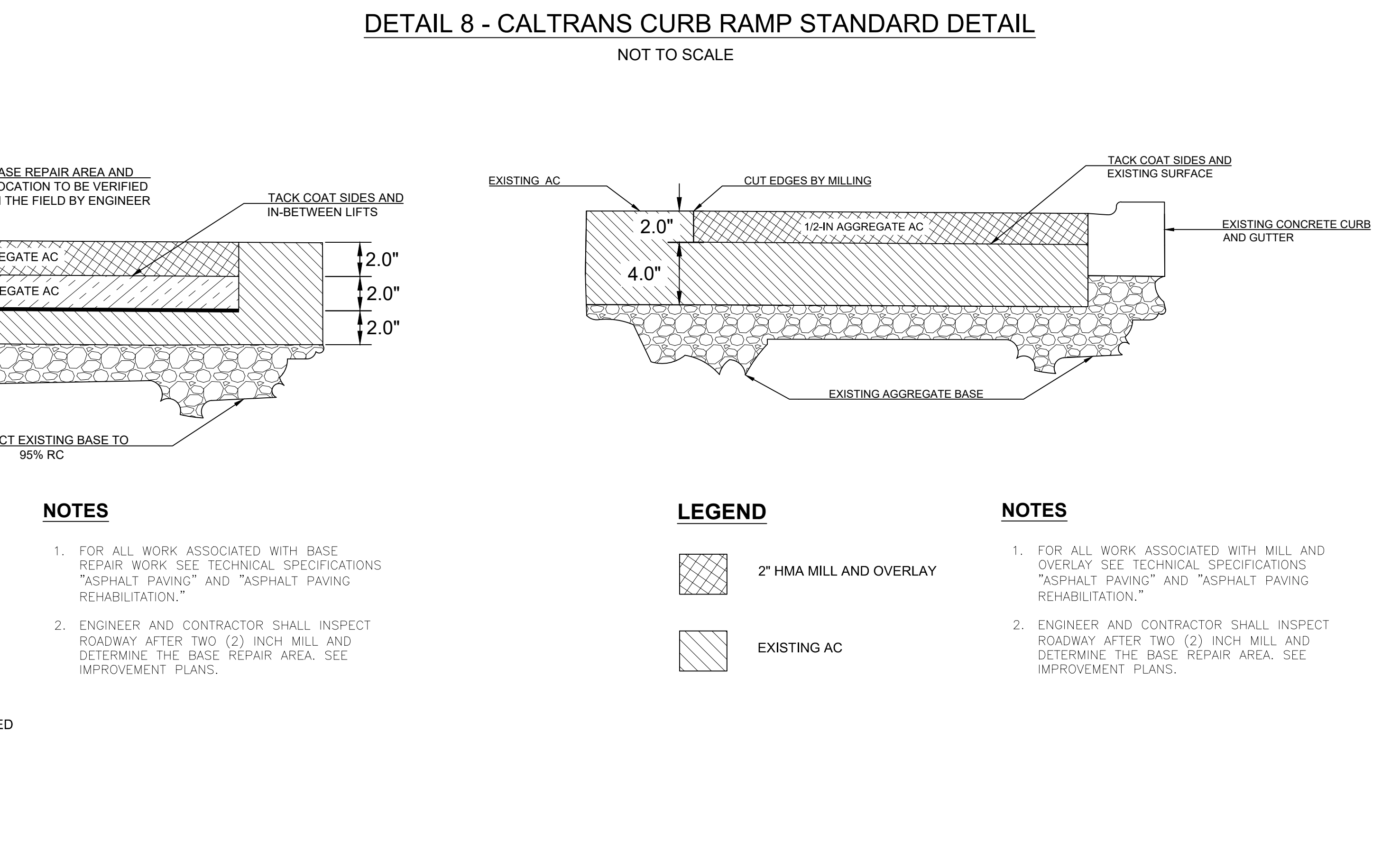
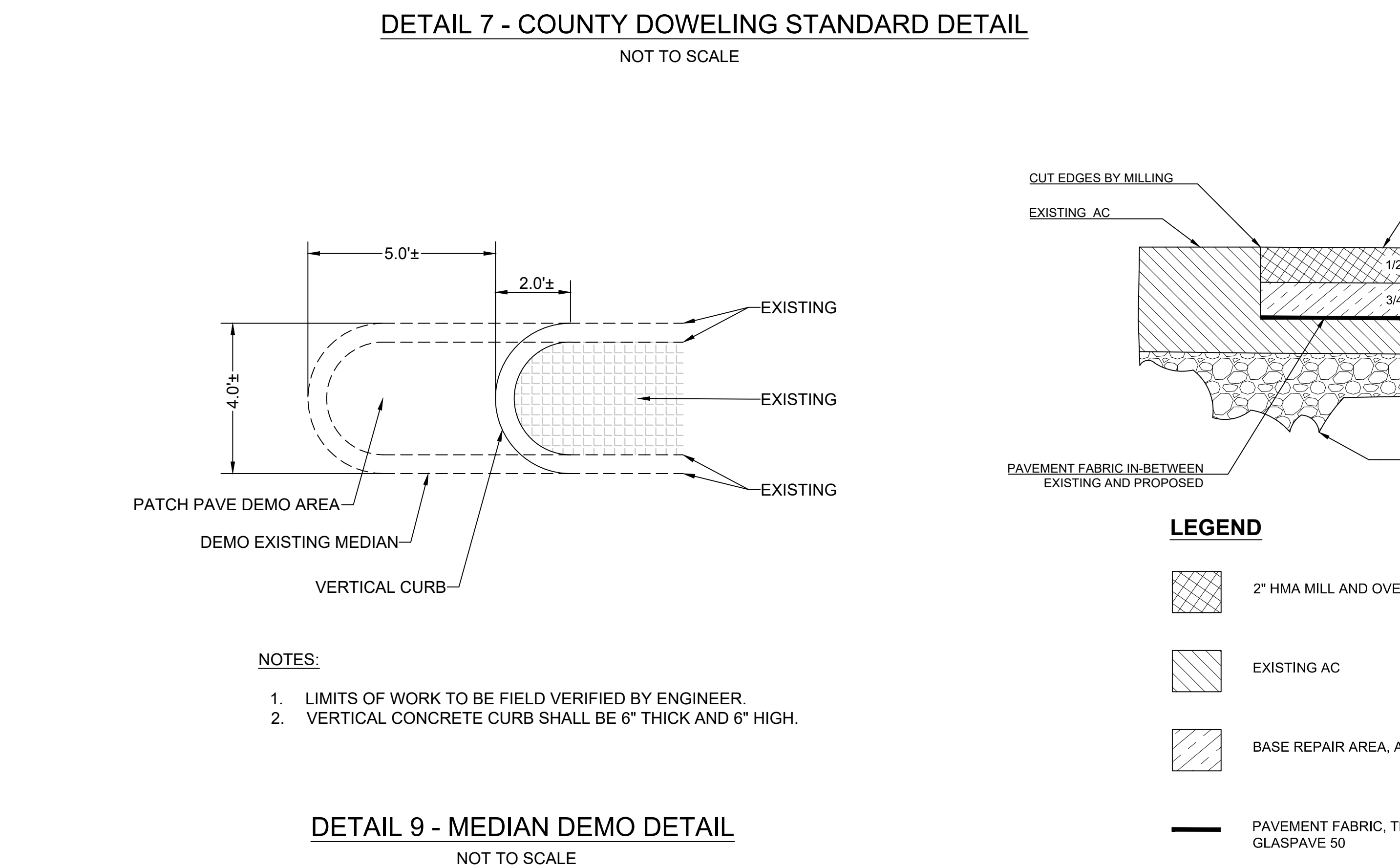
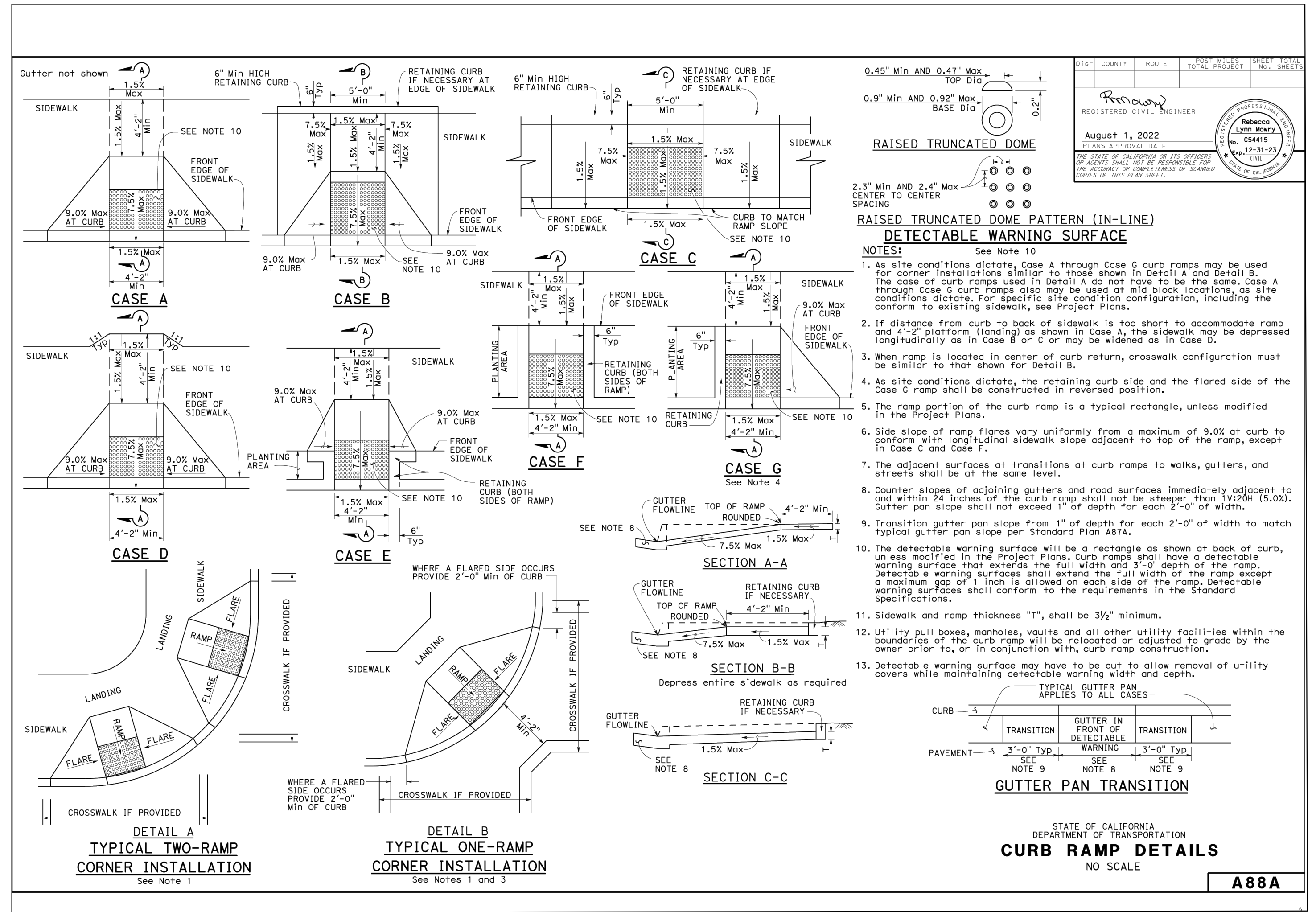
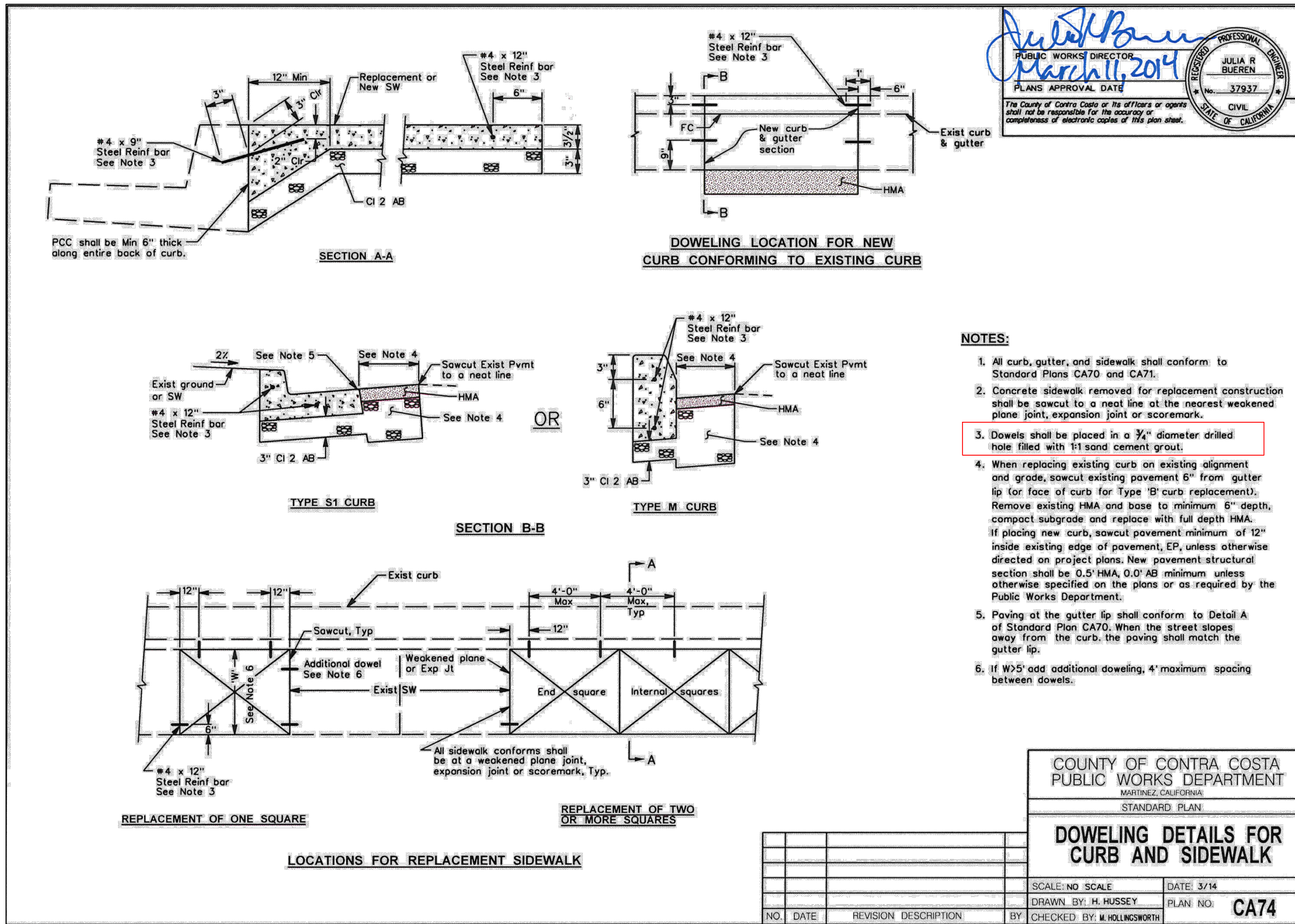

PROFESSIONAL ENGINEER
JULIA R. BUEREN
REGISTERED CIVIL ENGINEER
August 1, 2022
August 1, 2022
August 1, 2022

PREPARED UNDER THE DIRECTION OF:
7/12/23
Date
JOHN SAMUELSON
RCE 057734

City of Pittsburg

PROJECT 2241
E LELAND ROAD PAVEMENT MAINTENANCE
PROJECT DETAILS

BY	DESCRIPTION

DATE	REV	DESCRIPTION

SHEET: 14 OF 15
SHEET NO. CD-2

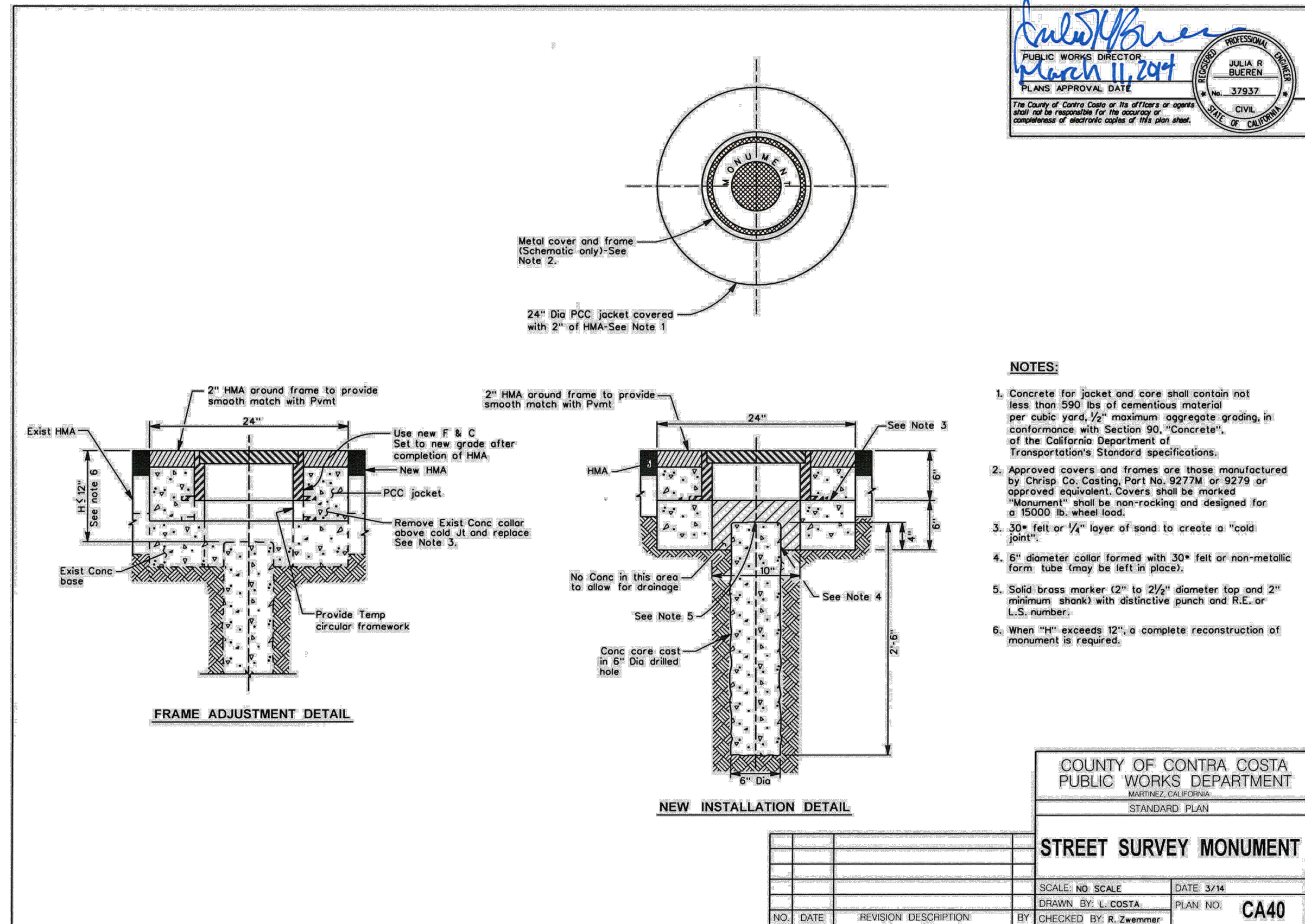

DETAIL 12 - ADJUST SURVEY MONUMENT TO GRADE
 NOT TO SCALE

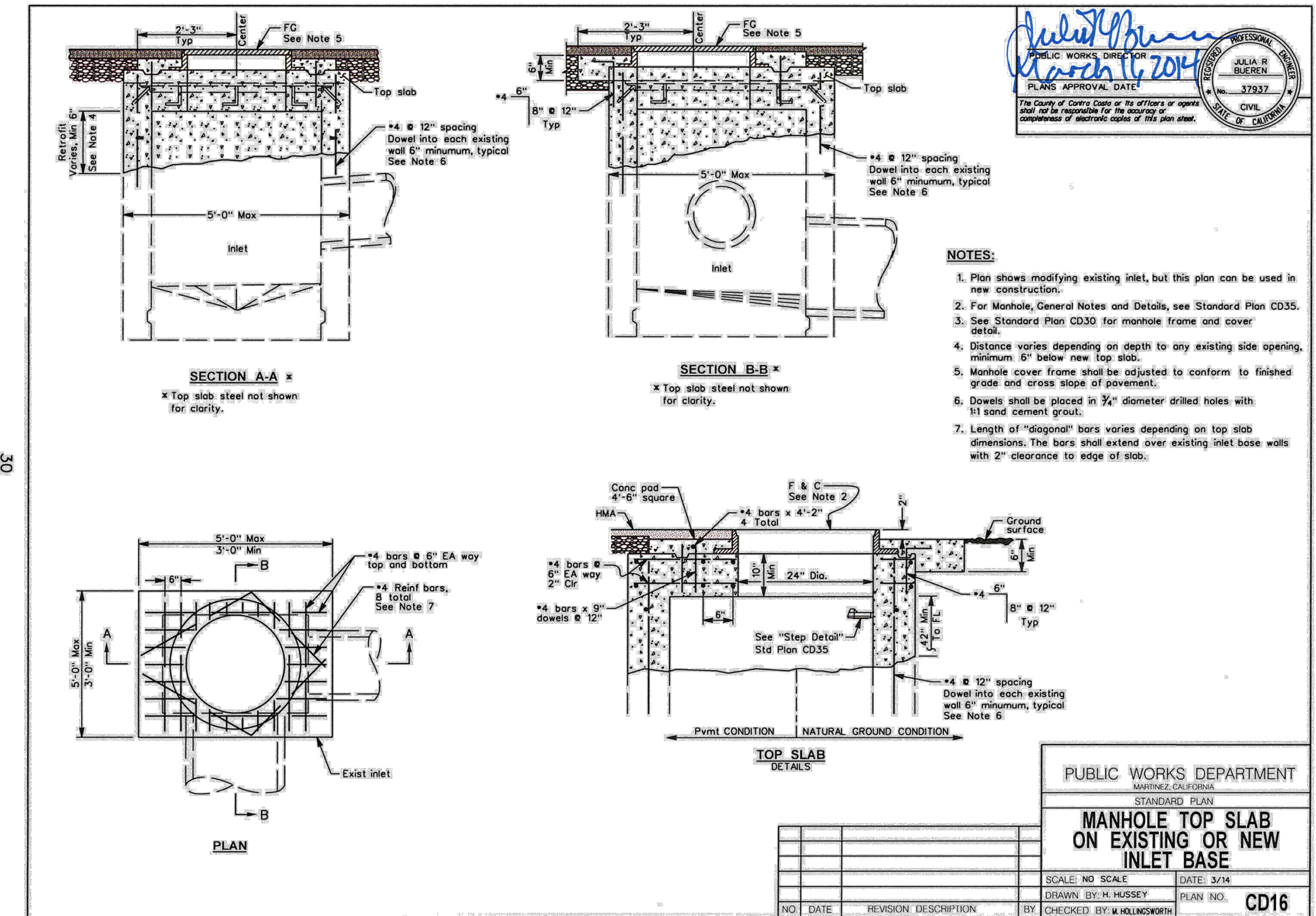

DETAIL 13 - ADJUST MANHOLE TO GRADE
 NOT TO SCALE

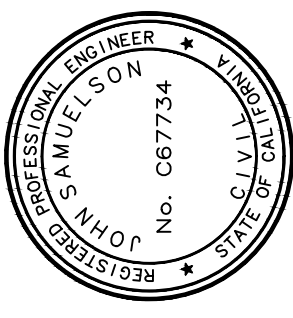

PREPARED UNDER THE DIRECTION OF:
 JOHN SAMUELSON
 RCE C67734
 Date: 7/12/23

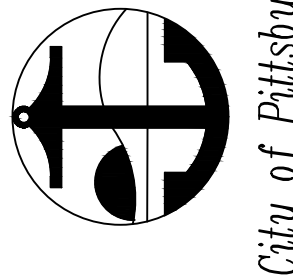

PROJECT 2241
 E LELAND ROAD PAVEMENT MAINTENANCE
 PROJECT DETAILS

NO.	DATE	REVISION DESCRIPTION	BY

SHEET:
 15 OF 15
 SHEET NO.
 CD-3